

WSSCLC-MOUNT WEIGHING ASSEMBLY (U.S. & METRIC)

The WSSCLC-MOUNT is a complete weighing assembly for use with the WSSCLC range of load cells (see separate data sheet). The weighing assembly facilitates easy mounting for the engineer on site, and incorporates a number of key features that allows the best installed accuracy to be achieved. These include an anti-lift off mechanism, compensation for thermal expansion and for off-axis loading.

Manufactured from stainless steel, the WSSCLC-MOUNT is available in three sizes (assembly instructions are shown on the reverse of this data sheet). The unit is equipped with self load alignment to mitigate against positioning errors and deformation.

FEATURES & BENEFITS

- Stainless steel construction
- Ensures best installation accuracy is achieved
- Incorporates a safety retainer to prevent accidental vessel lifting or sliding
- Available in three sizes
- Suitable for use with the WSSCLC load cell series

TOP VIEW

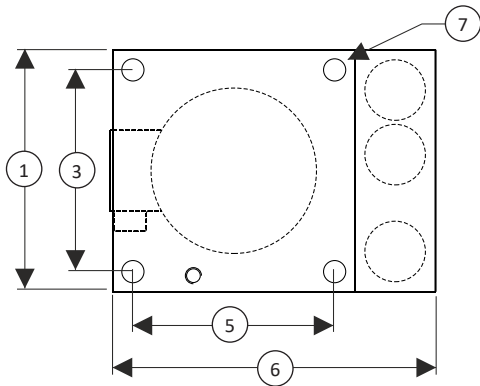

STANDARD CONFIGURATION

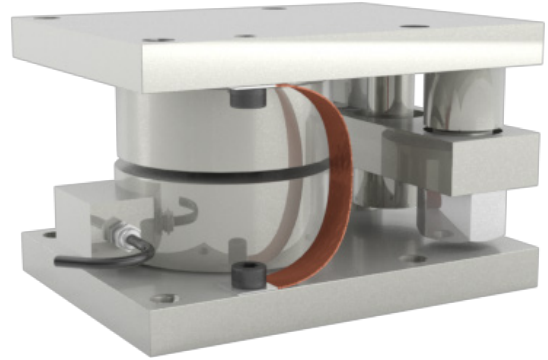

MODEL WSSCLC-MOUNT-1 (Shown)

TYPICAL APPLICATIONS

- Vessel weighing
- Silo weighing
- Process weighing & control
- Tank weighing

SIDE VIEW

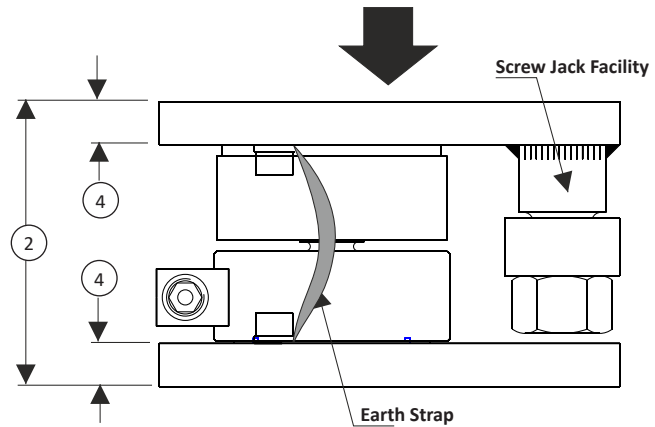

DIMENSIONS

SEE DRAWING	U.S. (lbf)	Metric (kg)	U.S. (lbf)	Metric (MT)	U.S. (lbf)	Metric (MT)	U.S. (lbf)	Metric (MT)
		220, 551, 1.1K, 2.2k, 5.5k, 11k, 16.5k	100, 250, 500, 1K, 2.5K, 5K, 7.5K	20K	10	44K, 66.1K	20, 30	110.2K, 165.3K, 220.4K
	in	mm	in	mm	in	mm	in	mm
(1)	4.72	120	4.72	120	7.87	200	10.6	270
(2)	3.93	100	3.93	100	4.4	112	5.3	135
(3)	3.93	100	3.93	100	6.29	160	8.4	214
(4)	0.59	15	0.59	15	0.59	15	0.59	15
(5)	3.93	100	3.93	100	4.33	110	6.8	174
(6)	6.29	160	6.29	160	7.87	200	11.8	300
(7)	∅ 0.43	∅ 11	∅ 0.43	∅ 11	∅ 0.7	∅ 18	∅ 0.98	∅ 25
Weight	15.4 (lbs)	7 (kg)	15.4 (lbs)	7 (kg)	30.8 (lbs)	14 (kg)	68.3 (lbs)	31 (kg)

Datasheet: WSSCLC-MOUNT v1.101-28-2021

U.S. dimensions and capacities are provided for conversion only. Standard products have International System of Units (SI) capacities and dimensions.

WSSCLC-MOUNT WEIGHING ASSEMBLY (U.S. & METRIC)

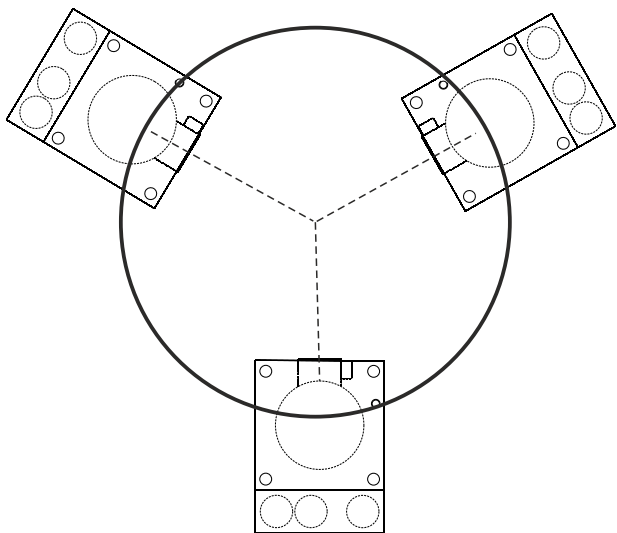

Circular system with three supporting points

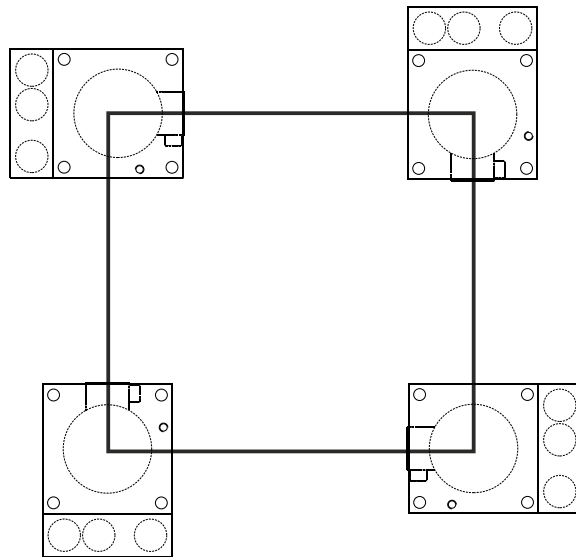

Square system with four supporting points

Model		WSSCLC-MOUNT-1				WSSCLC-MOUNT-2		WSSCLC-MOUNT-3	
Capacity		U.S. (lbf)	Metric (kg)	U.S. (lbf)	Metric (MT)	U.S. (lbf)	Metric (MT)	U.S. (lbf)	Metric (MT)
		220 - 16.5K	100 - 7.5K	20K	10	44K - 66.1K	20 - 30	110.2K - 220.4K	50 - 100
Nominal load	lbf	22K				66.1K		220.4K	
	MT	10				30		100	
Maximum permissible horizontal force	lbf	5.6				11.2		26.9	
	kN	25				50		120	
Maximum permissible lifting force	lbf	8.9				17.9		47.2	
	kN	40				80		210	

ASSEMBLY INSTRUCTIONS

- Fix the WSSCLC-MOUNT loading plate (1) to the structure or to the floor, checking that the floor is flat and even. If not, use separate leveling plates.
- Place the system to be weighed on the upper plates (2), taking care that the load cells are not overloaded.
- Adjust and fix the upper plate (2), ensuring that it is parallel and in axis with the lower plate.
- Check that the safety retainer (3) is centered inside the hole, ensuring that it is free to move, especially during weighing.

LOAD CELL REPLACEMENT

- Lift the weighing units upper plate (2) by unscrewing the two lifting jacks (4), ensuring that the upper plate is jacked evenly.
- Replace the load cell
- Screw the two jacks (4) to lower the upper plate evenly back onto the load cells



Alava Ingenieros
GRUPO ALAVA

tel: +34 915 679 700
www.alavaingenieros.com | alava@grupoalava.com