

WMCFP MINIATURE SEALED STAINLESS STEEL LOAD CELL (U.S. & METRIC)

FEATURES & BENEFITS

- Capacities from 500 to 1000 gf (1.10 to 2.20 lbf)
- Proprietary Interface temperature compensated strain gages
- Tension and compression
- Environmentally sealed
- Overload protected to 8x capacity

SPECIFICATIONS

Capacities	Metric (gf)	500	1000
	U.S. (lbf)	1.10	2.20
ACCURACY – (MAX ERROR)			
Nonlinearity – %FS		±0.20	
Hysteresis – %FS		±0.20	
Nonrepeatability – %RO		±0.05	
Creep, in 20 min – %		±0.05	
TEMPERATURE			
Compensated Range	°C	-10 to +45	
	°F	+15 to +115	
Operating Range	°C	-54 to +121	
	°F	-65 to +250	
Effect on Output – % / deg	°F	±0.002	
Effect on Zero – %RO / deg	°F	±0.005	
ELECTRICAL			
Rated Output – mV/V (Nominal)		1.0	
Zero Balance – %RO		±2.0	
Bridge Resistance – Ohm (Nominal)		350	
Excitation Voltage – VDC MAX		7	
Insulation Resistance – Megohm		> 5000	
MECHANICAL			
Calibration		Tension	
Safe Overload – %CAP		800	
Deflection @RO	mm	0.013	0.003
	in	0.005	0.001
Weight	kg	0.09	
	lbs	0.2	

OPTIONS

- Cable length
- Special calibration
- Standardized output
- Special temperature range
- Custom calibration
- Add connector to cable
- Transducer Electronic Data Sheet (TEDS)

ACCESSORIES

- Instrumentation

STANDARD CONFIGURATION



Model WMCFP (Shown)

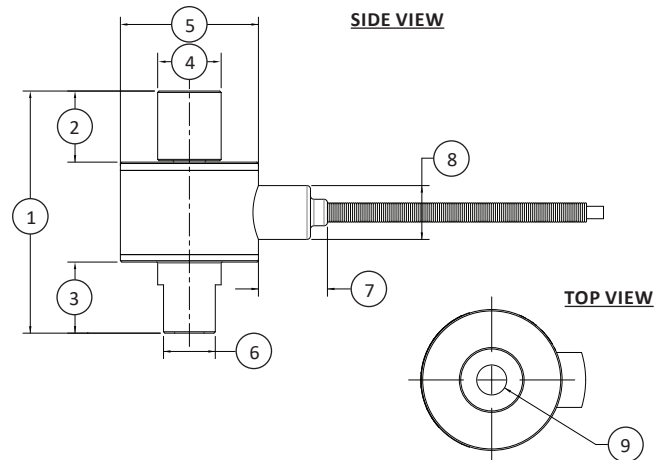

DIMENSIONS

See Drawing	CAPACITY	
	Metric (gf)	U.S. (lbf)
	500, 1000	1.10, 2.20
	mm	in
(1)	44.5	1.75
(2)	13.2	0.52
(3)	13.2	0.52
(4)	∅11.7	∅0.46
(5)	∅25.4	∅1.00
(6)	∅9.5	∅0.38
(7)	12.7	0.50
(8)	9.9	0.39
(9)	0.250-28 UNF ↓ 0.32	

CONNECTOR OPTIONS

- 1.5 m (5 ft) integral cable

International System of Units (SI) dimensions and capacities are provided for conversion only. Standard products have U.S. capacities and dimensions. SI capacities available upon special request and at an additional cost.