

MODEL WMCP, WMC (CAPACITIES 500gf thru 50Klbf) INSTALLATION INFORMATION

PHYSICAL DESCRIPTION

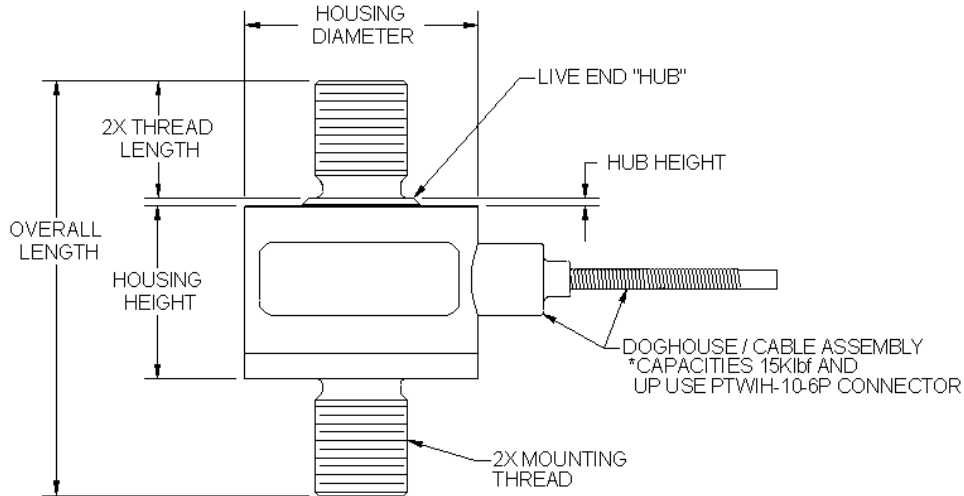

WMCP SERIES / WMC SERIES INSTALLATION TORQUE

CAPACITY		MODEL / CAPACITY			
		WMCP SERIES	WMC SERIES		
		500, 1000	5, 10	25, 50, 100	250, 500, 1000
	lbf				
	gf				
	N				
HOUSING DIAMETER	in (mm)	1.00 (25.4)	0.75 (19.1)	1.00 (25.4)	1.00 (25.4)
OVERALL LENGTH	in (mm)	1.36 (34.5)	1.01 (25.7)	1.05 (26.7)	1.32 (33.5)
HOUSING HEIGHT	in (mm)	0.75 (19.1)	0.45 (11.4)	0.52 (13.2)	0.53 (13.4)
HUB HEIGHT	in (mm)	0.11 (2.8)	0.06 (1.5)	0.03 (0.8)	0.03 (0.8)
HUB DIAMETER	in (mm)	0.37 (9.4)	0.31 (7.9)	0.37 (9.4)	0.34 (8.6)
MOUNTING THREAD		#6-32 UNC-3A	#6-32 UNC-3A	#10-32 UNC-3A	0.250-28 UNF-3A
THREAD LENGTH	in (mm)	0.25 (6.4)	0.25 (6.4)	0.25 (6.4)	0.38 (9.7)
MAX RECOMMENDED	in-lb	15	10	40	100
SEATING TORQUE	Nm	1.7	1.1	4.5	11

WMCP SERIES / WMC SERIES INSTALLATION TORQUE (CONTINUED)

CAPACITY		MODEL / CAPACITY			
		WMC SERIES			
		2000, 3000	5000	7500, 10K	15K, 20K, 30K, 50K
	lbf				
	gf				
	N				
HOUSING DIAMETER	in (mm)	1.00 (25.4)	1.25 (31.8)	1.38 (34.9)	2.50 (63.5)
OVERALL LENGTH	in (mm)	1.75 (44.5)	2.23 (56.6)	2.88 (73.2)	6.50 (165.1)
HOUSING HEIGHT	in (mm)	0.72 (18.3)	0.94 (23.9)	1.09 (27.7)	2.47 (62.7)
HUB HEIGHT	in (mm)	0.03 (0.8)	0.03 (0.8)	0.03 (0.8)	0.03 (0.8)
HUB DIAMETER	in (mm)	0.45 (11.5)	0.58 (14.7)	0.88 (22.3)	1.68 (42.7)
MOUNTING THREAD		0.375-24 UNF-3A	0.500-20 UNF-3A	0.750-16 UNF-3A	1.500-12 UNF-2A
THREAD LENGTH	in (mm)	0.50 (12.7)	0.63 (16.0)	0.88 (22.4)	2.00 (50.8)
MAX RECOMMENDED	in-lb	400	400	400	5000
SEATING TORQUE	Nm	45	45	45	565

MECHANICAL INSTALLATION NOTES

1. Installation must provide each mounting thread at least one thread diameter amount of engagement. Additional thread engagement is always more desirable.
2. Mating hardware does not have to be jammed against either the load cell hub or base end for proper performance.
3. If mating hardware is jammed against either the load cell hub or base end, adhere to the maximum recommended seating torque values listed in the above tables. For lower capacities up through 100lbf, the base end of the housing can be safely clamped with modest holding force for reacting torque at the live end and preventing rotation of the housing. Utilize pads or soft jaws to prevent marring of the body. Wrench flats are not provided.
4. For thread jamming mating hardware onto capacities of 250lbf and above, it is recommended that a tension preload be applied to the fully engaged mating assembly prior to applying a modest cinching torque to fully seat the mating components. Consult "Torque Versus Clamping Load" tables or formulae with the appropriate material-based friction coefficient for comparing the preload to the maximum recommended seating torque in the above tables. Do not exceed the maximum safe axial load listed in the specifications for the load cell. Upon release of the tension preload, a residual clamping load will remain in the mated interfaces. Reapply the same tension preload prior to un-jamming the hardware for disassembly and removal.
5. Never use the cable, doghouse assembly or connector for reacting against installation or disassembly torques.
6. Jam nuts or equivalent may be employed provided that a full thread diameter of engagement is accommodated in each and every component as described in Note 1.
7. With the base end of the load cell on the "fixed" side of the load string, the force to be measured should be applied to the active end of the cell to eliminate possible errors due to cable motion and interaction.

ELECTRICAL INFORMATION

1. WMCP and WMC models from low capacities up through 10Klbf possess a 4-conductor shielded Teflon® cable (AWG 30), 5 feet (1.5m) long. Wiring Color Code complies with ISA S37.8 Δ Specifications and Tests for Strain Gage Force Transducers® and WMC Load Cell Terminology.
2. The following provides the connector pinouts for standard WMC model load cells for capacities of 15Klbf through 50Klbf. Connector type: PTWIH-10-6P

PIN	FUNCTION
A	+ EXCITATION
B	+ SENSE
C	- EXCITATION
D	- SENSE
E	- SIGNAL
F	+ SIGNAL

CONNECTOR PINOUT

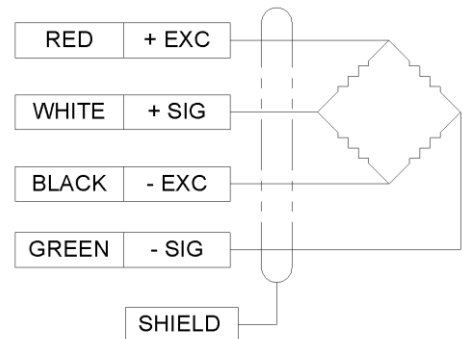

TENSION UPSCALE

PERFORMANCE DATA

WMCP / WMC LOAD CELL

Capacity	500gf	1000gf	5lbf	10lbf	25-500lb	1000lbf	2K-10Klbf	15K-50Klbf
Rated Output, Nom. (mV/V)	0.75	1.50				2.00		
Input Resistance (Ohms)	350 ± 3.5							
Output Resistance (Ohms)	350 ± 3.5							
Recommended Excitation (VDC)	5				10			
Non-Linearity, Max. (% Rated Output)	0.15					0.20	0.10	
Hysteresis, Max. (% Rated Output)	0.15					0.20	0.10	
Temp. Range Compensated	50 - 150 °F			15 - 115 °F				
Temp. Effect on Zero, Max. (% Rated Output/100°F)	2.00	1.00				0.50	0.25	



Edificio Antalia, Albasanz 16, 28037 Madrid
 915 679 700 | grupoalava.com | alava@grupoalava.com
 MADRID - BARCELONA - ZARAGOZA - LISBOA - DALLAS - MIAMI - LOS ANGELES - LIMA

WARRANTY & CERTIFICATION STATEMENT ON OTHER SIDE