

SSMF FATIGUE RATED S-TYPE LOAD CELL (U.S. & METRIC)

FEATURES & BENEFITS

- Fatigue-rated: 1×10^7 fully reversed cycles
- Proprietary Interface temperature compensated strain gages
- Capacities 25 to 2.5K lbf (100 to 10K N)
- Environmentally sealed
- 0.02% nonrepeatability
- Near zero temp. effect on output – 0.0008%/°F (0.0015%/°C)
- Very low creep – 0.025%
- Tension and compression

SPECIFICATIONS

ACCURACY – (MAX ERROR)		
Nonlinearity – %FS		±0.05
Hysteresis – %FS		±0.03
Nonrepeatability – %RO		±0.02
Creep, in 20 min – %		±0.025
TEMPERATURE		
Compensated Range	°F	0 to +150
	°C	-15 to +65
Operating Range	°F	-65 to +200
	°C	-55 to +90
Effect on Output – % / deg	°F	±0.0008
	°C	±0.0015
Effect on Zero – %RO / deg	°F	±0.0015
	°C	±0.0027
ELECTRICAL		
Rated Output – mV/V (Nominal)		1.5
Zero Balance – %RO		±1.0
Bridge Resistance – Ohm (Nominal)		350
Excitation Voltage – VDC MAX		15
Insulation Resistance – Megohm		> 5000
MECHANICAL		
Calibration		Tension
Safe Overload – %CAP		300
Deflection	in	0.002 to 0.003
	mm	0.05 to 0.08
Nat. Freq (Hz)		1500 to 3300
Fatigue-Rated		1×10^7 fully reversed loading cycles
Material	25 -500 lbf	Aluminum
	100 - 2.5K N	
	1K - 2.5K lbf	Alloy steel
	5K - 10K N	

STANDARD CONFIGURATION

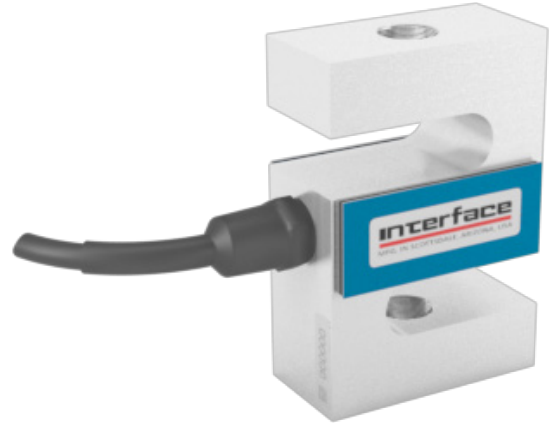

Model SSMF (Shown)

OPTIONS

- RC04E-10-6P connector – 250 lbf (11.1 kN) & higher on load cell body
- Standardized output
- Special temperature range
- Cable length
- Add connector cable
- Transducer Electronic Data Sheet (TEDS)

ACCESSORIES

- Instrumentation
- Mounting hardware
- Load button

CONNECTOR OPTIONS

- 10 ft (3 m) integral cable

International System of Units (SI) dimensions and capacities are provided for conversion only. Standard products have U.S. capacities and dimensions. SI capacities available upon special request and at an additional cost.

SSMF FATIGUE RATED S-TYPE LOAD CELL (U.S. & METRIC)

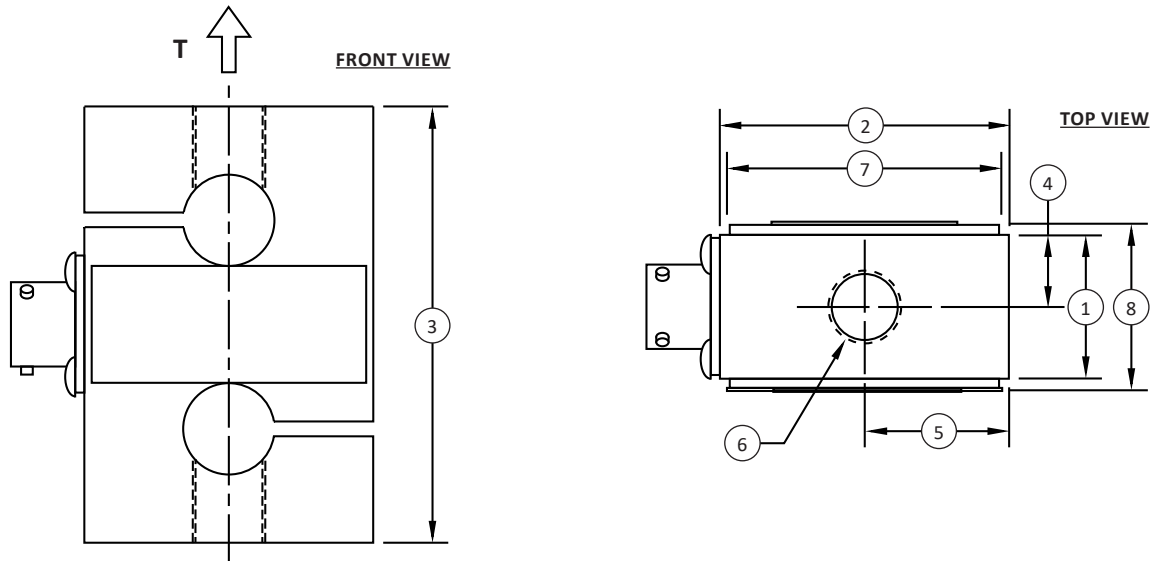

Notes:
* T indicates tension load direction / primary axis

DIMENSIONS

See Drawing	CAPACITY							
	U.S. (lbf)	Metric (N)	U.S. (lbf)	Metric (N)	U.S. (lbf)	Metric (N)	U.S. (lbf)	Metric (N)
	in	mm	in	mm	in	mm	in	mm
(1)	0.50	12.7	0.50	12.7	1.00	25.4	1.50	38.1
(2)	2.00	50.8	2.00	50.8	2.00	50.8	2.50	63.5
(3)	2.50	63.5	2.50	63.5	3.00	76.2	3.50	88.9
(4)	0.25	6.40	0.25	6.40	0.50	12.7	0.75	19.1
(5)	1.00	25.4	1.00	25.4	1.00	25.4	1.25	31.8
(6)	¼-28 UNF-2B	M6 x 1-6H	¼-28 UNF-2B	M6 x 1-6H	½-20 UNF-2B	M12 x 1.75-6H	¾-18 UNF-2B	M16 x 2-6H
(7)	1.88	47.8	1.88	47.8	1.88	47.8	2.38	60.5
(8)	0.82	20.8	0.72	18.3	1.22	31.0	1.75	44.5