

Installation Information LBM Load Cells

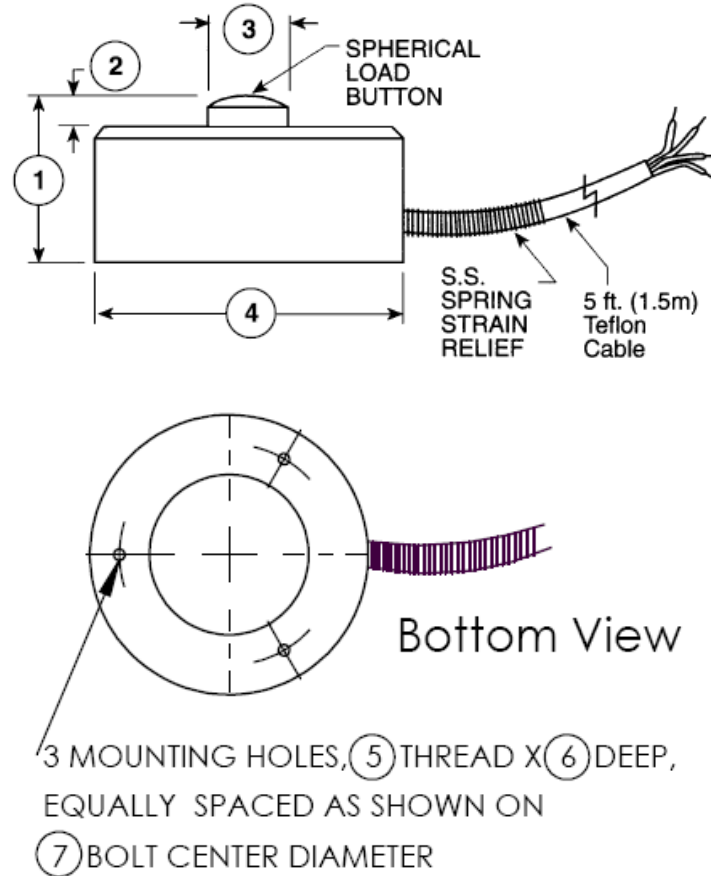

Table 1- Flexure Dimensions and Mounting Torque

See Drawing	LBM Series									
	CAPACITY (lbf)									
	25, 50, 100		250, 500, 1K, 2K		5K, 10K		20K		50K	
	inch	mm	inch	mm	inch	mm	inch	mm	inch	mm
(1)	0.62	15.7	0.39	9.90	0.63	16.00	1.00	25.4	1.50	38.1
(2)	0.05	1.30	0.07	1.80	0.08	2.00	0.12	3.00	0.18	4.60
(3)	0.21	5.30	0.32	8.10	0.43	10.9	0.60	15.00	0.78	19.8
(4)	1.00	25.4	1.25	31.8	1.50	38.1	2.00	50.8	3.00	76.2
(5)	4-40 UNC		6-32 UNC		6-32 UNC		6-32 UNC		6-32 UNC	
(6)	0.19	4.83	0.25	6.35	0.25	6.35	0.25	6.35	0.25	6.35
(7)	0.75	19.00	1.00	25.4	1.25	31.8	1.63	41.3	2.38	60.3
	MAX SAFE MOUNTING TORQUE									
	12 in-lb	1.3 Nm	34 in-lb	3.8 NM	34 in-lb	3.8 NM	34 in-lb	3.8 NM	34 in-lb	3.8 NM

Installation Instructions

1. Interface LBM Series Load Cells must be mounted on a suitable surface that is flat and rigid enough so as to not deform appreciably under load. The mounting surface should have a minimum hardness of Rc 33-35, be clean, and free of paint or grease. The mounting surface should be perpendicular to the load axis within 1 degree and flat to 0.0005in.
2. Interface Load Cells respond to forces in the axis perpendicular to the mounting surface. Load Cell response to non-axial forces is proportional to that force times the cosine of the angle it makes with the loading axis.
3. Load application is implemented via the convex load button on top of the force transducer. The component applying force to load button should be ground and have a hardness of at least Rc 40.
4. Minimum of Grade 8 or Class 10.9 screws should be used when installing the Load Cell. Torque the screws as indicated in Table 1.

