

## GMW90 Series Carbon Dioxide, Temperature, and Humidity Transmitters

for Demand Controlled Ventilation Applications



### Features

- Measured parameters: carbon dioxide, temperature, and humidity (optional)
- Superior long-term stability with the next generation Vaisala CARBOCAP® sensor
- Accurate temperature and humidity measurements due to the low-power microglow infrared source
- Quick and easy installation and maintenance
- Calibrated, user-exchangeable measurement modules
- 3-point traceable CO<sub>2</sub> calibration (certification included)
- Both analog and digital communication (BACnet®/Modbus®)

GMW90 Series Carbon Dioxide, Temperature and Humidity Transmitters for HVAC are available with either a display opening or a solid front. An optional traffic light indication can also be selected.

GMW90 Series CARBOCAP® Carbon Dioxide, Temperature, and Humidity Transmitters are based on new measurement technology for improved reliability and stability. With the new technology the transmitter's inspection interval is extended to five years. Designed for demand controlled ventilation, these transmitters measure carbon dioxide and temperature, with the option for humidity measurements. The instruments come with a calibration certificate that meets traceability and compliance requirements.

### Reliability from Unique Measurement Technology

GMW90 series transmitters use advanced Micro-Electro-Mechanical System (MEMS) technology for measuring carbon dioxide. The CARBOCAP® carbon dioxide

sensor's continuous reference measurement enables reliable and accurate readings and outstanding long-term stability also in buildings with round-the-clock occupancy.

The new generation CARBOCAP® sensor no longer uses an incandescent light bulb, which limits sensor lifetime. This unique sensor consumes very little power compared to other sensors on the market. As a result, instrument self-heating is low and humidity and temperature can be measured correctly.

### Convenient Installation

GMW90 series transmitters have been designed for quick and easy installation and maintenance. Every model includes a display for easy startup and convenient maintenance. To protect the sensor from dust and dirt during construction and installation, the units can be cabled with

back-plate only. Electronics can be snapped on later at an appropriate phase in the construction project. DIP switches make it quick and easy to configure the transmitters.

### Easy Calibration

Regular instrument maintenance guarantees a long product lifetime. Calibration is easiest done with the exchangeable measurement modules. Sensor traceability and measurement quality is easily maintained by snapping on a new module calibrated at Vaisala factory. The instrument can also be calibrated using a hand-held meter or reference gas CO<sub>2</sub> bottle. The service interfaces are easy to reach by simply sliding the cover down. The closed cover keeps the measurement environment stable during calibration and ensures a top-quality final result.

# Technical Data

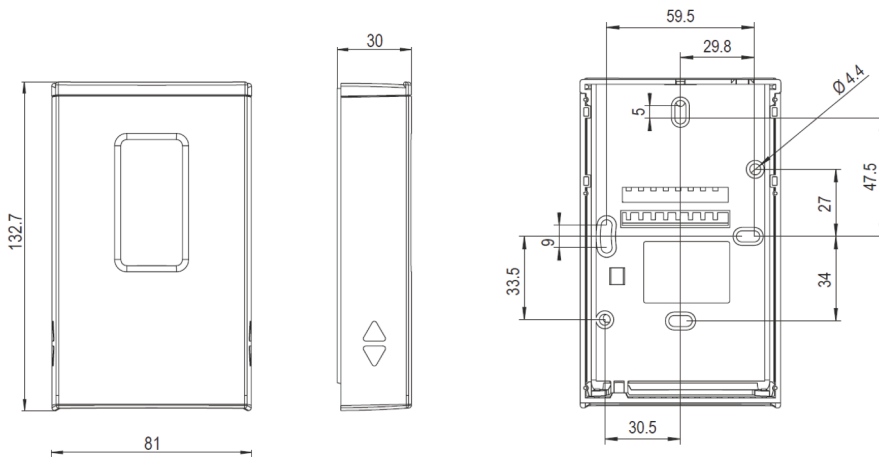

Dimensions in mm

## Models

Model	Measurements	Output
GMW93	CO <sub>2</sub> +T	3-wire, voltage output
GMW93D	CO <sub>2</sub> +T	3-wire, voltage output with display
GMW94	CO <sub>2</sub> +T	3-wire, current output
GMW94D	CO <sub>2</sub> +T	3-wire, current output with display
GMW93R	CO <sub>2</sub> +T+RH	3-wire, voltage output
GMW93RD	CO <sub>2</sub> +T+RH	3-wire, voltage output with display
GMW93RA	CO <sub>2</sub> +T+RH	3-wire, voltage output with display and CO <sub>2</sub> indicator LEDs
GMW94R	CO <sub>2</sub> +T+RH	3-wire, current output
GMW94RD	CO <sub>2</sub> +T+RH	3-wire, current output with display
GMW95	CO <sub>2</sub> +T	Digital (BACnet/Modbus) model
GMW95D	CO <sub>2</sub> +T	Digital (BACnet/Modbus) model with display
GMW95R	CO <sub>2</sub> +T+RH	Digital (BACnet/Modbus) model
GMW95RD	CO <sub>2</sub> +T+RH	Digital (BACnet/Modbus) model with display
GMW90	CO <sub>2</sub> +T	Configurable analog/digital models
GMW90R	CO <sub>2</sub> +T+RH	Configurable analog/digital models

# Technical Data

## Measurement Performance

### Carbon Dioxide

Measurement range	0 ... 5000 ppm
Stability in typical HVAC applications	Total accuracy at room temperature ±75 ppm at 600 and 1000 ppm incl. 5 years drift
Carbon dioxide sensor	Vaisala CARBOCAP® GM10
Accuracy:	
+20 ... +30 °C (+68 ... +86 °F)	±(30 ppm + 2 % of reading)
+10 ... +20 °C, +30 ... +40 °C (+50 ... +68 °F, +86 ... +104 °F)	±(35 ppm + 2.7 % of reading)
-5 ... +10 °C, +40 ... +55 °C (+23 ... +50 °F, +104 ... +131 °F)	±(45 ppm + 3.8 % of reading)

### Temperature

Measurement range	-5 ... +55 °C (+23 ... +131 °F)
Temperature sensor	Digital temperature sensor
Accuracy:	
+20 ... +30 °C (+68 ... +86 °F)	±0.5 °C (±0.9 °F)
+10 ... +20 °C, +30 ... +40 °C (+50 ... +68 °F, +86 ... +104 °F)	±0.6 °C (±1.08 °F)
-5 ... +10 °C, +40 ... +55 °C (+23 ... +50 °F, +104 ... +131 °F)	±0.8 °C (± 1.44 °F)

### Relative Humidity

Measurement range	0 ... 95 %RH
Stability in typical HVAC applications	±0.5 %RH/year
Humidity sensor	Vaisala HUMICAP® 180R
Accuracy at temperature range +10 ... +40 °C (+50 ... +104 °F):	
0 ... 60 %RH	±2.5 %RH
60 ... 80 %RH	±3.0 %RH
80 ... 95 %RH	±4.0 %RH
Accuracy at temperature range -5 ... +10 °C, +40 ... +55 °C (+23 ... +50 °F, +104 ... +131 °F):	
0 ... 60 %RH	±3.5 %RH
60 ... 80 %RH	±4.0 %RH
80 ... 95 %RH	±5.0 %RH

1) Complies with CEC-400-2008-001-CMF

## Operating Environment

Operating temperature	-5 ... +55 °C (+23 ... +131 °F)
Storage temperature	-30 ... +60 °C (-22 ... +140 °F)
Operating humidity	0 ... 95 %RH
Dew point	< +30 °C (+86 °F)

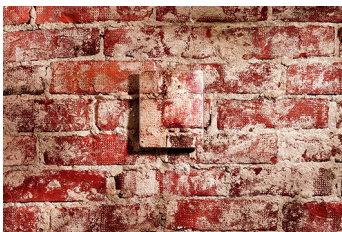

Optional decorative cover blends the transmitter into your interior design.

**VAISALA**

www.vaisala.com

 Alava Ingenieros  
GRUPO ALAVA

tel: +34 915 679 700  
www.alavaingenieros.com | alava@grupoalava.com

## Inputs and Outputs

Supply voltage	18 ... 35 VDC, 24 VAC ± 20% 50/60 Hz
Service port	RS-485 line for temporary service use

### Current Output Models

Outputs	0/4 ... 20 mA, 2 and 3 channel models
Loop resistance	0 ... 600 Ω
Power consumption	< 2 W

### Voltage Output Models

Outputs	0 ... 5/10 V, 2 and 3 channel models
Load resistance	10 kΩ min.
Power consumption	< 1 W

### Default Analog Scales

CO <sub>2</sub>	0 ... 2000 ppm
T	-5 ... +55 °C
RH	0 ... 100 %RH

### Digital Models

Power consumption	< 1.5 W
Output type	RS-485 (galvanic isolation, 1.5 kV)
RS-485 end of line termination	Enable with jumper, 120 Ω

Supported protocols (selectable by DIP switch):

BACnet® MS/TP (selectable Master/Slave)	Address range, master mode: 0 ... 127 Address range, slave mode: 128 ... 255
Modbus® RTU	Address range: 0 ... 247

## Mechanical Specifications

Standard housing color	White (RAL9003)
Housing material	ABS/PC, UL-V0 approved
Output connector	Screw terminals Max. wire size 2 mm <sup>2</sup> (AWG14)
Service port connector	4-pin M8
Weight	163 g (5.75 oz)

1) RAL code is only indicative with potential small variations in color shade

## Spare Parts and Accessories

CO <sub>2</sub> module	GM10SP
Temperature Module (CO <sub>2</sub> +T models)	TM10SP
Humidity and Temperature Module (CO <sub>2</sub> +T+RH models)	HTM10SP
Decorative cover set (10 pcs)	236285
Connection cable for M170	219980
USB cable for PC connection	219690

## Compliance

EMC compliance	EN61326-1, Industrial Environment
IP rating	IP30



Published by Vaisala | B211296EN-E © Vaisala 2017

All rights reserved. Any logos and/or product names are trademarks of Vaisala or its individual partners. Any reproduction, transfer, distribution or storage of information contained in this document is strictly prohibited. All specifications — technical included — are subject to change without notice.