

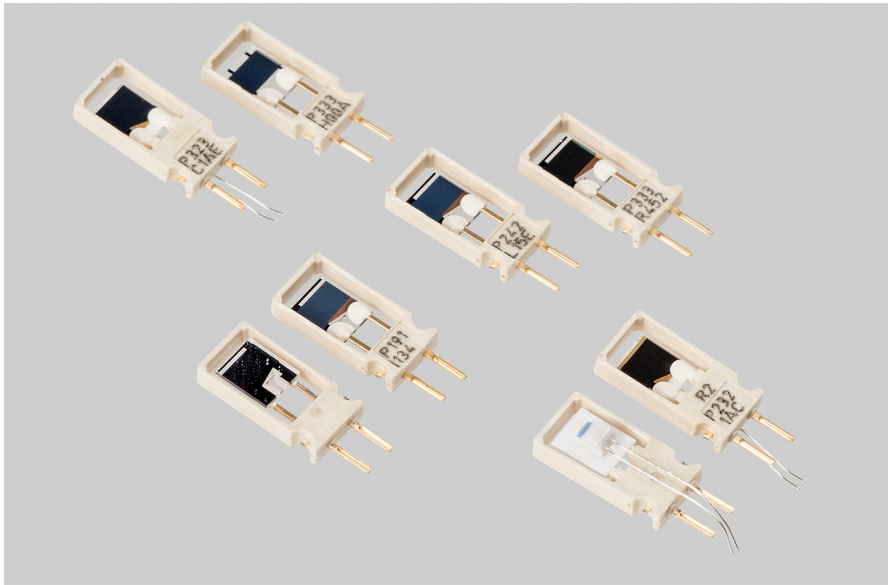

HUMICAP® Sensors

For measuring relative humidity



Features

- A capacitive thin-film polymer sensor
- Full measurement range 0 ... 100 %RH
- Accurate to ± 0.8 %RH ¹⁾
- Traceable humidity measurement
- Over 40 years on the market

1) Accuracy up to ± 0.8 %RH depending on product

Vaisala HUMICAP® sensors guarantee quality and reliability, with their reputation for accuracy, excellent long-term stability, and negligible hysteresis.

Benefits

- Excellent long-term stability
- Insensitive to dust and most chemicals
- Chemical purge option for stable measurements in environments with high concentrations of chemicals
- Sensor heating for measurements even in condensing environments
- Full recovery from condensation

How the HUMICAP® sensor works

HUMICAP® is a capacitive thin-film polymer sensor consisting of a substrate on which a thin film of polymer is deposited between two conductive electrodes. The sensing surface is coated with a porous metal electrode to protect it from contamination and exposure to condensation. The substrate is typically glass or ceramic. The thin-film polymer either absorbs or releases water vapor as the relative humidity of the ambient air rises or falls. The dielectric properties of the polymer film depend on the amount of absorbed water. As the relative humidity around the sensor changes, the dielectric properties of the polymer film change, and so does the capacitance of the sensor. The instrument's electronics measure the capacitance of the sensor and convert it into a humidity reading.

Vaisala HUMICAP® humidity products

Vaisala has everything you need for measuring humidity, with a wide range of humidity instruments covering applications from HVAC to the most demanding industrial applications, both indoors and out. Vaisala's humidity instrument offering includes transmitters, modules for volume applications, portable and handheld humidity meters, and humidity calibrators.

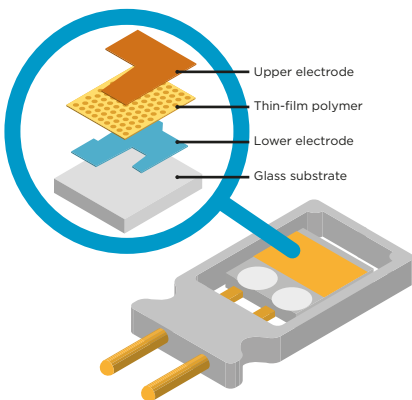

Humidity sensor types

INTERCAP®	Interchangeable general purpose humidity sensor with good humidity durability and short response time.
HUMICAP® 180C	Composite ¹⁾ general purpose humidity sensor with good humidity durability and short response time. The item contains humidity and temperature sensors. This sensor is used for chemical purge and heated probe options.
HUMICAP® 180R	Robust general purpose humidity sensor with high humidity durability, good long term stability, and good tolerance against chemical exposure.
HUMICAP® 180RC	Robust composite general purpose humidity sensor. The HUMICAP® 180RC has high humidity durability, good long term stability, and good tolerance against chemical exposure. The item contains humidity and temperature sensors. This sensor is used for chemical purge and heated probe options.
HUMICAP® 180L2	Moisture measurement sensor for liquids. It has good tolerance against chemicals and moderate humidity durability.
HUMICAP® H3K	47 pF general purpose humidity sensor that is used in some older products.
HUMICAP® R2	The latest generation industrial humidity sensor. Compared to HUMICAP® 180R it has improved corrosion resistance.
HUMICAP® 180V	Humidity sensor with a catalytic surface for use in processes with H₂O₂.
HUMICAP® 180VC	Composite humidity sensor with catalytic surface for use in processes with H₂O₂.
	After the latest sensor update, the INTERCAP® sensor has been upgraded to the same environmental tolerance as the old HUMICAP® 180. Please use spare part item 15778HM for products using the HUMICAP® 180 sensor.

1) With integral Pt100 sensor

Sensor properties

	Integral Pt100 temp. sensor	Encapsulation type	Identifying character	Item code
INTERCAP®		Type C	I	15778HM (1 pc) INTERCAPSET-10PCS (10 pcs)
HUMICAP® 180C	X	Type C	I	229011SP
HUMICAP® 180R		Type C	R	HUMICAP180R
HUMICAP® 180RC	X	Type C	R	HUMICAP180RC
HUMICAP® H3K		Type C	H	HUMICAPK
HUMICAP® 180L2		Type D	L	HUMICAP180L2
HUMICAP® R2		Type D	R2	HUMICAPR2
HUMICAP® 180V		Type D	V	HUMICAP180V
HUMICAP® 180VC	X	Type D	C	HUMICAP180VC

Technical data

Materials

- All materials comply with UL V-0
- Thin film capacitor structure on glass substrate (Type C) or alumina (Type D)
- Sensor frame is made of lubricated 30 % glass reinforced LCP resin (white LCP Zenite 6130L)
- Sensor pin material is copper alloy with electroplated gold coating
- Sensor chip is attached to pins using silver-filled epoxy glue
- Glue is protected with white thermal curing marking ink

Dimensions

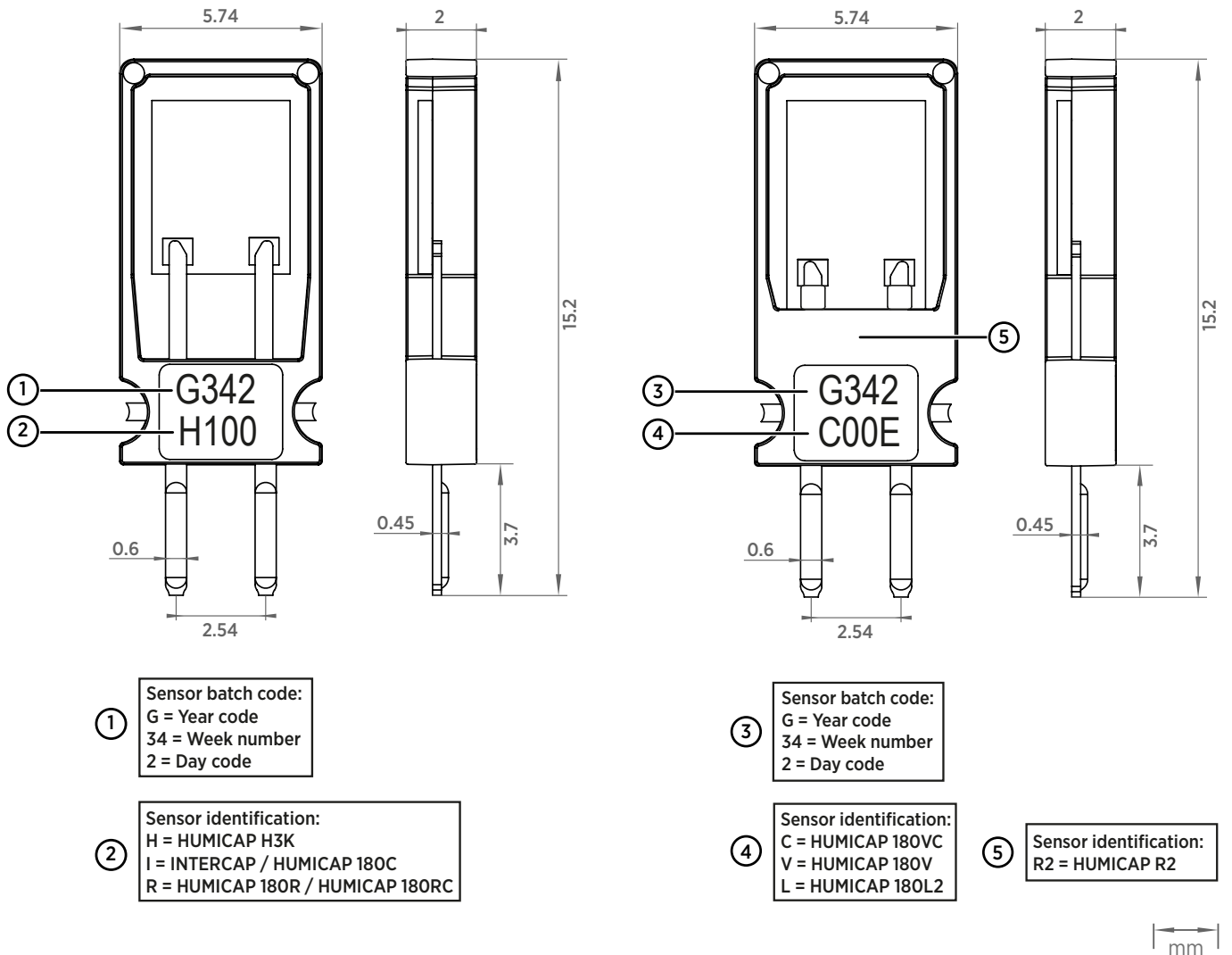

Type C (left) and type D (right) encapsulation dimensions

VAISALA

www.vaisala.com

Published by Vaisala | B211748EN-B © Vaisala Oyj 2020

All rights reserved. Any logos and/or product names are trademarks of Vaisala or its individual partners. Any reproduction, transfer, distribution or storage of information contained in this document is strictly prohibited. All specifications – technical included – are subject to change without notice.