

# User Guide

Vaisala HUMICAP<sup>®</sup> Humidity and Temperature  
Module  
**HMM170**

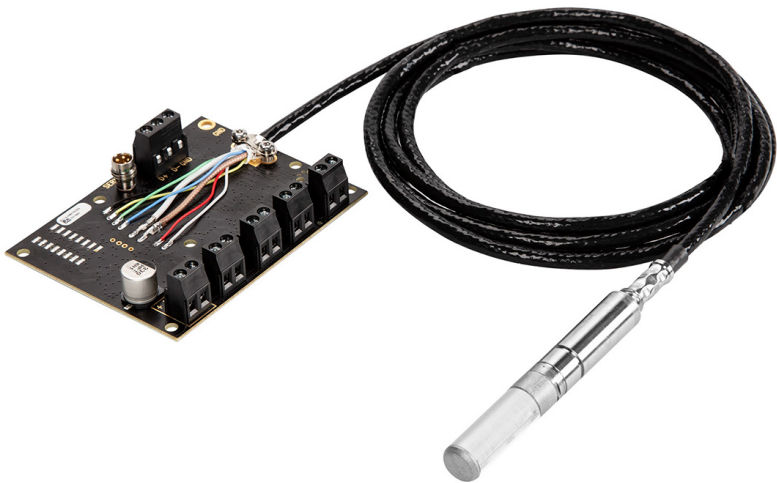

## PUBLISHED BY

Vaisala Oyj  
Vanha Nurmijärventie 21, FI-01670 Vantaa, Finland  
P.O. Box 26, FI-00421 Helsinki, Finland  
+358 9 8949 1

Visit our Internet pages at [www.vaisala.com](http://www.vaisala.com).

© Vaisala 2020

No part of this document may be reproduced, published or publicly displayed in any form or by any means, electronic or mechanical (including photocopying), nor may its contents be modified, translated, adapted, sold or disclosed to a third party without prior written permission of the copyright holder. Translated documents and translated portions of multilingual documents are based on the original English versions. In ambiguous cases, the English versions are applicable, not the translations.

The contents of this document are subject to change without prior notice.

Local rules and regulations may vary and they shall take precedence over the information contained in this document. Vaisala makes no representations on this document's compliance with the local

rules and regulations applicable at any given time, and hereby disclaims any and all responsibilities related thereto.

This document does not create any legally binding obligations for Vaisala towards customers or end users. All legally binding obligations and agreements are included exclusively in the applicable supply contract or the General Conditions of Sale and General Conditions of Service of Vaisala.

This product contains software developed by Vaisala or third parties. Use of the software is governed by license terms and conditions included in the applicable supply contract or, in the absence of separate license terms and conditions, by the General License Conditions of Vaisala Group.

## Table of contents

<b>1.</b>	<b>About this document</b> .....	5
1.1	Version information.....	5
1.2	Related manuals.....	5
1.3	Documentation conventions.....	5
1.4	Trademarks.....	6
<b>2.</b>	<b>Product overview</b> .....	7
2.1	Introduction to HMM170.....	7
2.2	Basic features and options.....	7
2.3	Sensor types.....	8
2.4	Output parameters.....	9
2.5	Probe head.....	10
2.6	Chemical purge.....	11
2.7	Filter types.....	11
2.8	LED indicator.....	12
2.9	Safety.....	12
2.9.1	ESD protection.....	12
2.10	Regulatory compliances.....	13
<b>3.</b>	<b>Installation</b> .....	14
3.1	Installing module.....	14
3.2	Selecting probe mounting location and method.....	15
3.3	Installing probe.....	16
<b>4.</b>	<b>Operation</b> .....	17
4.1	Using service port.....	17
4.1.1	Installing driver for the USB service cable.....	17
4.2	Modbus.....	18
4.3	Vaisala Insight Software.....	18
4.3.1	Connecting to Insight software.....	18
4.3.2	Configuration options.....	19
<b>5.</b>	<b>Maintenance</b> .....	20
5.1	Cleaning probe.....	20
5.2	Replacing filter.....	20
5.3	Calibration and adjustment.....	21
5.3.1	Adjustment points and requirements.....	22
5.3.2	Adjusting measurement with Insight software.....	22
<b>6.</b>	<b>Technical data</b> .....	24
6.1	HMM170 specifications.....	24
6.2	Dimensions.....	26
6.3	Accessories and spare parts.....	27
<b>Appendix A: Modbus reference</b> .....		<b>29</b>
A.1	Default communication settings.....	29

- A.2 Function codes..... 29
- A.3 Data encoding..... 29
  - A.3.1 32-bit floating point or integer format..... 30
  - A.3.2 16-bit integer format..... 30
- A.4 Modbus registers..... 31
  - A.4.1 Measurement data registers..... 31
  - A.4.2 Configuration registers..... 34
  - A.4.3 Device identification objects..... 36
  - A.4.4 Status registers..... 37
  - A.4.5 Test value registers..... 39
- A.5 Exception responses..... 39
- A.6 Modbus communication examples..... 40
  
- Warranty..... 43**
  
- Technical support..... 43**
  
- Recycling..... 43**

## List of figures

Figure 1	HMM170 probe head dimensions.....	10
Figure 2	HMM170 component board.....	14
Figure 3	HMM170 probe installation through a wall.....	15
Figure 4	Connecting module to Insight.....	19
Figure 5	Temperature measurement accuracy over temperature range.....	25
Figure 6	HMM170 probe head dimensions.....	26
Figure 7	HMM170 component board dimensions.....	27

## List of tables

Table 1	Document versions (in English).....	5
Table 2	Related manuals.....	5
Table 3	HMM170 sensor types.....	8
Table 4	Availability of output parameters.....	9
Table 5	Filter types and properties.....	11
Table 6	LED indicator states.....	12
Table 7	Measurement performance.....	24
Table 8	Operating environment.....	25
Table 9	Inputs and outputs.....	25
Table 10	Mechanical specifications.....	26
Table 11	Accessories.....	27
Table 12	Spare parts.....	27
Table 13	Default Modbus communication settings.....	29
Table 14	Modbus function codes.....	29
Table 15	Interpretation of 16-bit signed integer values.....	30
Table 16	Modbus measurement data registers (Read-Only).....	31
Table 17	Modbus configuration data registers (writable).....	34
Table 18	Device identification objects.....	36
Table 19	Modbus status data registers (read-only).....	37
Table 20	Error codes in register 0203 <sub>hex</sub> .....	38
Table 21	Modbus test registers (read-only).....	39
Table 22	Modbus exception responses.....	39

# 1. About this document

## 1.1 Version information

This document provides instructions for installing, operating, and maintaining Vaisala HUMICAP® Humidity and Temperature Module HMM170.

Table 1 Document versions (in English)

Document code	Date	Description
M212259EN-C	April 2020	Updated technical specification, installation instructions, and Modbus reference appendix. HMM170 now supports 24 VAC supply voltage, starting from serial number S1231134.
M212259EN-B	October 2019	Updated section <a href="#">Output parameters (page 9)</a> . Updated technical specification. Removed content related to MI70 handheld indicator.
M212259EN-A	June 2019	First version.

## 1.2 Related manuals

Table 2 Related manuals

Document code	Name
M212260EN	HMM170 Quick Guide
M210185EN	HMK15 User guide

## 1.3 Documentation conventions



**WARNING! Warning** alerts you to a serious hazard. If you do not read and follow instructions carefully at this point, there is a risk of injury or even death.



**CAUTION! Caution** warns you of a potential hazard. If you do not read and follow instructions carefully at this point, the product could be damaged or important data could be lost.



**Note** highlights important information on using the product.



**Tip** gives information for using the product more efficiently.



Lists tools needed to perform the task.



Indicates that you need to take some notes during the task.

## 1.4 Trademarks

Vaisala® and HUMICAP® are registered trademarks of Vaisala Oyj.

All other product or company names that may be mentioned in this publication are trade names, trademarks, or registered trademarks of their respective owners.



## 2. Product overview

### 2.1 Introduction to HMM170

Vaisala HUMICAP® Humidity and Temperature Module HMM170 is an open frame OEM module for integration into demanding environmental chambers and harsh conditions. The module provides a digital RS-485/Modbus RTU output and three freely configurable analog output channels. The module provides relative humidity, temperature, dew point, and other calculated parameters.

HMM170 probe covers the full temperature range  $-70 \dots +180 \text{ }^\circ\text{C}$  ( $-94 \dots +356 \text{ }^\circ\text{F}$ ) used in climate chambers and the whole humidity range up to condensation. The small probe and compact component board offer easy and flexible installation. The probe cable options (2, 5, or 10 m (6.5, 16.4, or 32.8 ft)) offer excellent cost optimization and flexibility to any OEM application. By ordering HMM170 with the appropriate sensor, you can use the module in environments that are frequently sterilized with vaporized hydrogen peroxide ( $\text{H}_2\text{O}_2$ ) or to measure humidity in oil medium, for example, for transformer and engine monitoring applications.

The latest general purpose HUMICAP® R2 sensor has improved corrosion resistance. The sensor can tolerate typical chemicals, such as cleaning agents used in climate chambers. The automatic sensor chemical purge function keeps the sensor clean from typical chemical fumes and the additional probe warming function prevents condensation. In case HMM170 gets in contact with water, the automatic heating rapidly dries the sensor to enable fast and accurate humidity measurement.

HMM170 is easy to install and convenient to use. It provides both digital and analog outputs for multiple needs. An integrated service port enables a quick and simple way to configure, check, and calibrate the module with the help of a USB cable and Vaisala Insight PC software. In addition, the footprint of the HMM170 component board enables easy update for Vaisala HMM100 users.

### 2.2 Basic features and options

- Three humidity sensor types:
  - Vaisala HUMICAP® R2C (general use)
  - Vaisala HUMICAP® 180VC (for  $\text{H}_2\text{O}_2$  use)
  - Vaisala HUMICAP® 180L2 (for moisture in oil)
- Sensor purge provides superior chemical resistance
- Probe and sensor warming functions minimize condensation on probe
- Analog output options:
  - 0/4 ... 20 mA
  - 0/1 ... 5 V
  - 0 ... 5/10 V
- Probe cable lengths:
  - 2, 5, or 10 m (6.5, 16.4, or 32.8 ft)
- Various filter types

- Service port for maintenance
  - Optional USB cable for easy connection to Vaisala Insight software for configuration, diagnostics, and temporary online monitoring

## 2.3 Sensor types

HMM170 is available with three different sensor types.

Table 3 HMM170 sensor types

Sensor type	Description
HUMICAP® R2C	A general purpose industrial humidity sensor with high humidity durability, good long term stability, and good tolerance against chemical exposure.
HUMICAP® 180L2	<p>A sensor that is optimized for measurement of humidity in oil medium. It has good tolerance against chemicals and moderate humidity durability.</p> <p>HUMICAP® 180L2 sensor measures moisture in oil in terms of the water activity (<math>a_w</math>) and temperature (T). Water activity indicates directly whether there is a risk of free water formation. The measurement is also independent of oil type and age. In addition to water activity, HMM170 can output ppm, the average mass concentration of water in oil.</p> <p>HUMICAP® 180L2 sensor does not support probe heating or chemical purge.</p>
HUMICAP® 180VC	<p>A composite humidity sensor with catalytic surface for use in applications where the sensor is exposed to H<sub>2</sub>O<sub>2</sub> (hydrogen peroxide).</p> <p>Catalytic HUMICAP® 180VC sensor is a good choice when you want to measure RH between bio-decontamination cycles and you are not interested in saturation level of the air mixture during the bio-decontamination phase. Catalytic layer protects the sensor during the bio-decontamination phase. Catalytic layer catalyzes H<sub>2</sub>O<sub>2</sub> into water vapor and oxygen. Therefore, the sensing polymer detects only water vapor and shows correct relative humidity value.</p>

## 2.4 Output parameters

- Output parameter is available
- ◐ Output parameter is unavailable unless real temperature is written to Modbus register 0334<sub>hex</sub> from an external source
- Output parameter is locked (value stays at latest valid reading) until measurement is possible again
- Output parameter is not valid for sensor type

Table 4 Availability of output parameters

Output parameter	Output range	HUMICAP® R2C and 180VC sensor			HUMICAP® 180L2 sensor
		Normal Operation	During Heating	During Purge	
Relative humidity	0 ... 100 %RH	●	◐	○	–
Temperature	-70 ... +180 °C	●	◐	○	●
Dew point temperature	-80 ... +100 °C	●	●	○	–
Dew/frost point temperature	-80 ... +100 °C	●	●	○	–
Dew/frost point temperature at 1 atm	-80 ... +100 °C	●	●	○	–
Dew point temperature at 1 atm	-80 ... +100 °C	●	●	○	–
Absolute humidity	0 ... 600 g/m <sup>3</sup>	●	◐	○	–
Mixing ratio	0 ... 500 g/kg	●	●	○	–
Wet-bulb temperature	0 ... +100 °C	●	◐	○	–
Water concentration	0 ... 10 <sup>6</sup> ppm	●	●	○	–
Water vapor pressure	0 ... 1000 hPa	●	●	○	–
Water vapor saturation pressure	0 ... 1000 hPa	●	◐	○	–
Enthalpy	-40 ... 1500 kJ/kg	●	◐	○	–
Water activity	0 ... 1	–	–	–	●
Dew point temperature difference	-10 ... +50 °C	●	◐	○	–
Absolute humidity at NTP	0 ... 600 g/m <sup>3</sup>	●	◐	○	–
Water concentration in oil	0 ... 10 <sup>6</sup> ppm	–	–	–	●

Output parameter	Output range	HUMICAP® R2C and 180VC sensor			HUMICAP® 180L2 sensor
Relative saturation	0 ... 100 %RS	-	-	-	●
Water mass fraction	0 ... 10 <sup>6</sup> ppm <sub>w</sub>	●	●	○	-

## 2.5 Probe head

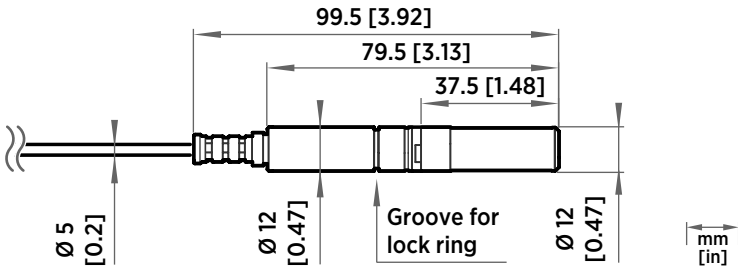

Figure 1 HMM170 probe head dimensions

HMM170 is designed for applications that involve constant high humidity or rapid changes in humidity, such as drying and test chambers, combustion air, and other humidifiers and meteorological measurements, where measurement performance and chemical tolerance are essential.

- Temperature measurement range -70 ... +180 °C (-94 ... +356 °F)
- Operating temperature range for probe -70 ... +180 °C (-94 ... +356 °F)
- Probe and sensor warming functions minimize condensation on probe
- Vapor and pressure proof construction
- Stainless steel mesh filter standard in delivery

### Probe heating

HMM170 supports probe heating. Probe heating heats up not only the sensor, but the entire probe head. When probe temperature is heated above dew point temperature, condensation on the probe can be avoided while measuring the dew point temperature of the process.

Probe heating is normally disabled. If you select to enable probe heating, output parameters that are dependent on temperature measurement (such as relative humidity) are disabled, unless the true temperature of the measured environment is updated to the temperature compensation register of the probe from another measurement instrument. Output parameters that can be measured or calculated without this external temperature information (such as dew point temperature) are available even without the temperature input.

## 2.6 Chemical purge

Chemical purge is a process where sensors are heated to remove possible contamination. Purge is essential for long-term performance and accuracy of the probe. Purge takes up to 6 minutes to complete, during which time measurements are not available.

Depending on the selected sensor, the purge is automatically performed:

- At probe start-up
- At probe start-up and after every 24 hours





HUMICAP® 180L2 sensor does not support chemical purge.

You can trigger a purge manually at any time with Vaisala Insight software or Modbus, or by closing the external purge trigger on the component board.

## 2.7 Filter types

All filters available for HMM170 are 12 mm (0.47 in) in diameter. Note the operational temperature range of each filter.

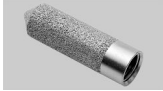
Table 5 Filter types and properties

	Filter type	Diameter	Pore size	Temperature range
	PPS plastic grid with stainless steel mesh	12 mm (0.47 in)	15 µm	-70 ... +180 °C (-94 ... +356 °F)
	Stainless steel sintered	12 mm (0.47 in)	38 µm	-70 ... +180 °C (-94 ... +356 °F)
	Stainless steel filter for moisture in oil	12 mm (0.47 in)	3.15 mm	-70 ... +180 °C (-94 ... +356 °F)
	Porous PTFE (general purpose)	12 mm (0.47 in)	8 µm	-70 ... +180 °C (-94 ... +356 °F)

### More information

- [Accessories and spare parts \(page 27\)](#)

## 2.8 LED indicator

The LED indicator on the component board provides a visual indication of the status of HMM170. The alarm LED functionality is preset at the factory according to order form.

Table 6 LED indicator states

LED color	Meaning
Not lit	Module is powered off or LED functionality is disabled.
Green	Module is powered on and ready for operation.
Green and blinking	Module is powering up or communicating using Modbus.
Red	Module is in error state.



You can use Vaisala Insight software to disable the LED indicator.

## 2.9 Safety

This product has been tested for safety. Note the following precautions:



**WARNING!** Ground the product and verify installation grounding periodically to minimize shock hazard.



**CAUTION!** Do not modify the unit or use it in ways not described in the documentation. Improper modification or use may lead to safety hazards, equipment damage, failure to perform according to specification, or decreased equipment lifetime.

### 2.9.1 ESD protection

Electrostatic Discharge (ESD) can damage electronic circuits. Vaisala products are adequately protected against ESD for their intended use. However, it is possible to damage the product by delivering electrostatic discharges when touching, removing, or inserting any objects in the equipment housing.

To avoid delivering high static voltages to the product:

- Handle ESD-sensitive components on a properly grounded and protected ESD workbench or by grounding yourself to the equipment chassis with a wrist strap and a resistive connection cord.

- If you are unable to take either precaution, touch a conductive part of the equipment chassis with your other hand before touching ESD-sensitive components.
- Hold component boards by the edges and avoid touching component contacts.

## 2.10 Regulatory compliances

HMM170 is in conformity with the provisions of the following EU directive(s):

- RoHS-Directive (2011/65/EU) and Directive 2015/863/EU amending Annex II to Directive 2011/65/EU

HMM170 is excluded from the scope of EMC-Directive (2014/30/EU) because it is an electronic module intended to be used only as a component by a professional manufacturer and not an “Apparatus” defined in Article 3 definition 1<sup>1)</sup> of EMC Directive.

---

1) *“Apparatus” means any finished appliance or combination thereof made available on the market as a single functional unit, intended for the end-user and liable to generate electromagnetic disturbance, or the performance of which is liable to be affected by such disturbance.*

## 3. Installation

### 3.1 Installing module

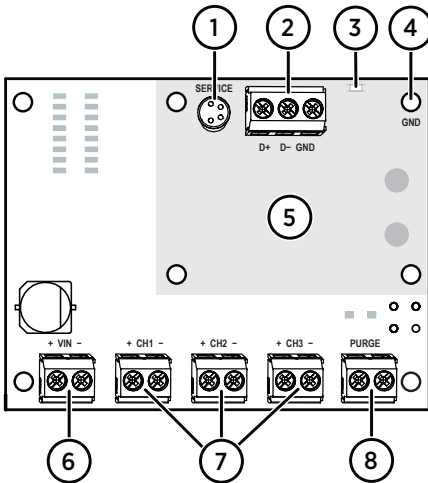

Figure 2 HMM170 component board

- 1 Service port (temporary connection, USB cable with Vaisala Insight software)
- 2 Digital RS-485 (Modbus) port
- 3 LED indicator
- 4 Grounding point
- 5 Mounting holes in the shaded area match the mounting holes on HMM100 humidity module
- 6 Power input (12 ... 35 VDC <sup>1)</sup> or 24 VAC  $\pm 10\%$ )
- 7 Active analog outputs (0/4 ... 20 mA, 1 ... 5 V, 0 ... 5/10 V)
- 8 External purge trigger (closing activates purge)

1) *Condensation prevention and chemical purge features require at least 18 VDC.*



**WARNING!** Make sure that you prepare and connect only de-energized wires.



**CAUTION!** Electrostatic Discharge (ESD) can cause immediate or latent damage to electronic circuits. Avoid touching exposed component contacts during installation and maintenance.

- ▶ 1. The module is delivered with a set of standoffs. Select the mounting holes you will be using, and attach standoffs to the corresponding locations on the installation surface. Always use the mounting hole marked **GND** as that is the grounding point for the module. You may use other applicable standoffs that provide a minimum installation height of 6 mm (0.24 in).
2. Attach the module securely.
3. Make sure that the module has a good earth connection from the grounding point.
4. Connect wiring to the power input and signal output terminals.
5. Optional: connect wiring to the external purge trigger terminals.



## 3.2 Selecting probe mounting location and method

Relative humidity measurement is sensitive to temperature differences between the probe and the measuring environment. Even a small temperature difference may cause a large error. For example, if the temperature is +20 °C (68 °F) and the relative humidity 100 %RH, a difference of  $\pm 1$  °C ( $\pm 1.8$  °F) between the environment and the probe causes an error of  $\pm 6$  %RH. For this reason, temperature differences are an important consideration when selecting the probe mounting location and method.

The probe location should represent well the environmental or process conditions, and it should be as clean as possible. The probe head can be installed completely into the measurement environment, or through a wall with only the filter (and the sensors underneath it) extending to the measurement environment.

- If the temperature of the measured environment differs greatly from ambient temperature, it is best to insert the whole probe and preferably plenty of cable inside the environment. This prevents measurement inaccuracy caused by heat conduction along the cable. The duct installation kit (Vaisala item code 210697) is a good accessory for this purpose as it allows the probe to be placed at a sufficient distance from the outer walls of the chamber or duct.
- If there is no temperature difference between the two sides of the installation wall, installing the probe through the wall is a good option.

Other considerations:

- Mount the probe head horizontally to prevent any water condensing on the probe head from running to the sensors.
- Let the cable hang loosely to prevent condensed water from running along the cable to the probe head.
- If you use probe heating, do not attach the probe directly to metal structures.

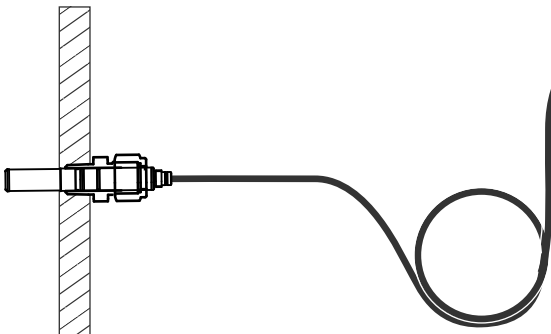

Figure 3 HMM170 probe installation through a wall

### 3.3 Installing probe



**CAUTION!** The measurement probe with cable is attached to the component board at Vaisala. Do not disconnect and reconnect the cable.

- ▶ 1. Remove the yellow protection cap from the probe.
2. Mount the probe head in the selected location using the applicable installation accessories. See any installation instructions that are delivered with the accessories.
3. Make sure any cable pass-throughs are sealed.

#### More information

- ▶ [Accessories and spare parts \(page 27\)](#)

## 4. Operation

### 4.1 Using service port

HMM170 has a 4-pin M8 service port connector on the component board. Vaisala offers an optional USB cable (Vaisala order code 219690) for connecting the module to your PC.



The service port is intended for short-term use such as calibration. For permanent installation, use the permanent digital Modbus and/or analog terminals.

If you have not used the HMM170 USB cable before, first install the driver.

#### 4.1.1 Installing driver for the USB service cable



Only Windows® operating systems are supported by the driver of the USB service cable.

- ▶ 1. Connect the USB service cable to a USB port on your computer. Windows® detects the new device and installs the appropriate driver.
2. Open **Devices and Printers** from the Windows® Start menu. Use search to find it if necessary (search for "devices").
3. Locate the cable in the list of devices:
  - If the device is listed as **Vaisala USB Device** with a COM port number in brackets, the cable is ready for use. **Note the COM port number, you will need it later.**
  - If the device is listed as **Vaisala USB Instrument Cable** without a COM port number listed, you must install the driver manually.

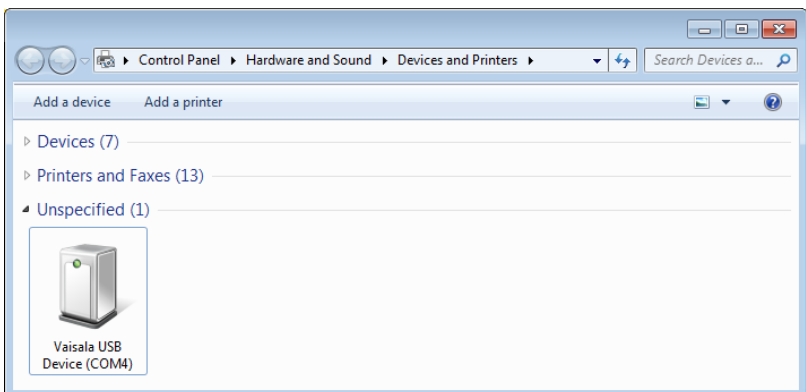

4. To install the driver manually:
  - a. Disconnect the USB service cable from the computer.
  - b. Download the Vaisala USB driver at <http://www.vaisala.com/software> (select the appropriate USB Instrument Driver Setup for your cable).
  - c. Run the USB driver installation program *Vaisala USB Device Driver Setup.exe*. Accept the installation defaults.
  - d. Go back to [step 1](#) and verify that the driver installation works as expected.

## 4.2 Modbus

The module can be accessed using the Modbus serial communication protocol. The supported Modbus variant is Modbus RTU (Serial Modbus) over RS-485 interface.

### More information

- [Modbus reference \(page 29\)](#)

## 4.3 Vaisala Insight Software

Vaisala Insight software is a configuration software for Indigo-compatible devices. The supported operating systems are Windows 7 (64-bit), Windows 8.1 (64-bit), and Windows 10 (64-bit).

With the Insight software, you can:

- See device information and status
- See real-time measurement
- Calibrate and adjust the device
- Configure device features such as measurement filtering, chemical purge, heating, and serial communication

Download Vaisala Insight software at [www.vaisala.com/insight](http://www.vaisala.com/insight).

HMM170 can be connected to Vaisala Insight software using a Vaisala USB cable (no. 219690).

### 4.3.1 Connecting to Insight software



- Computer with Microsoft Windows® operating system and Vaisala Insight software installed
- USB connection cable (order code 219690)

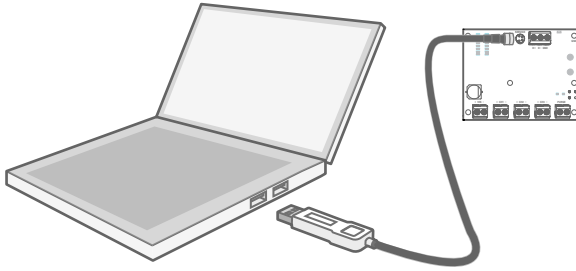



Figure 4 Connecting module to Insight

- ▶ 1. Open Insight software.
2. Connect the USB cable to a free USB port on the PC or USB hub.
3. Connect the USB cable to the service port of the module. The USB cable powers up the module.

### 4.3.2 Configuration options

Select  > **Configure Device** to access configuration options in Insight software.

The available configuration options correspond to the Modbus configuration registers. Insight software is the recommended way to change the device configuration.



You can restore the device back to its default settings using the **Factory Default Settings > Restore Settings** function. Doing this will also clear any user adjustment and restore the latest factory calibration.

#### More information

- [Modbus reference \(page 29\)](#)

## 5. Maintenance

### 5.1 Cleaning probe



- Lint-free cloth
- Isopropyl alcohol (70 %)



**CAUTION!** Do not attempt to clean the sensors under the filter in any way.

- ▶ 1. Moisten a lint-free cloth with isopropyl alcohol (70 %).
2. Wipe the probe head and cable with the lint-free cloth.



Do not spray anything directly on the probe head or immerse the probe head in liquid, since that may deposit impurities on the sensors.



Do not wipe the filter: wiping the filter may block its pores and/or deposit residue on the filter. If the filter is heavily contaminated, replace it.

3. After cleaning the probe, it is recommended to perform a chemical purge.

#### More information

- [Chemical purge \(page 11\)](#)
- [Replacing filter \(page 20\)](#)

### 5.2 Replacing filter



- New compatible filter
- Clean lint-free gloves



**CAUTION!** Without the filter in place, the sensor is easily damaged - handle the probe head carefully.

- ▶ 1. Put on clean gloves before touching the filter.
- 2. Turn the filter counter-clockwise to loosen it.
- 3. Remove the filter from the probe head. Be careful not to touch the sensor with the filter.
- 4. Install a new filter on the probe head. Tighten the filter properly (recommended force 5 Nm).

#### More information

- [Filter types \(page 11\)](#)
- [Accessories and spare parts \(page 27\)](#)

## 5.3 Calibration and adjustment

The module is fully calibrated and adjusted as shipped from the factory. To maintain the accuracy of the measurement, calibrate and adjust the module as needed. Typical calibration interval is one year, but depending on the application it may be necessary to check the accuracy more frequently.

When adjustment is necessary, you can have Vaisala calibrate and adjust the module. To order calibration services from Vaisala, visit [store.vaisala.com](https://store.vaisala.com). You can also do the adjustment yourself using the Insight software.



**WARNING!** When returning a product for calibration or repair, make sure it has not been exposed to dangerous contamination, and is safe to handle without special precautions.



If you think the device is not measuring correctly, calibration and adjustment is not the first thing to do. Check the following first:

- Make sure nothing is interfering with the measurement: heat sources, temperature differences, or condensation.
- Check that there is no moisture on the probe. If the sensor has become wet, wait for it to dry.
- Always wait for the measurement to stabilize.



**Calibration** means comparing the measurement output of the device to a known reference, such as a known environment in a calibration chamber or the output of a reference instrument. Correcting the reading of the device so that it measures accurately is referred to as **adjustment**.

### 5.3.1 Adjustment points and requirements

You can adjust the humidity measurement in 1 ... 5 points, and temperature measurement in 1 ... 2 points. Note the following:

- Humidity adjustment in more than two points is available when using Insight software in **Advanced Mode**.
- If you are adjusting in more than one humidity point, make sure the first two points are at least 10 %RH apart.
- The module will reject adjustments that are too large, that is, greater than 10 %RH for humidity and 0.5 °C (0.9 °F) for temperature. If the module appears to need such a large correction, perform a sensor purge and repeat the adjustment procedure. Make sure the measurement has stabilized and the reference environment is reliable. If the required adjustment is still too large, the module needs to be serviced by Vaisala.



When adjustment of humidity measurement is necessary, Vaisala recommends adjusting in two points, 11 %RH and 75 %RH. These humidities can be produced using the Vaisala HMK15 Humidity Calibrator. Adjustment of temperature measurement is typically not necessary.



### 5.3.2 Adjusting measurement with Insight software



- Computer with Windows operating system and Vaisala Insight software installed
- Vaisala USB cable 219690 for connecting the module
- Reference environment(s) for producing the desired humidity and/or temperature

This procedure can be used to adjust the module's humidity or temperature measurement. If you want to adjust both, repeat the procedure.

Because stabilization of temperature and humidity takes time, you should expect the adjustment procedure to take at least 30 minutes for each adjustment point.

- ▶ 1. Connect the module to Insight. See [Connecting to Insight software \(page 18\)](#).
2. If you intend to adjust humidity measurement, first select  > **Purge** to perform a chemical purge to condition the sensor. Wait a few minutes for purge to complete.
3. Select  > **Calibrate** > **Yes** to switch the module to calibration mode.  
In calibration mode, the device will not use functions that may interfere with calibration and adjustment.
4. Select the type of adjustment to perform: **RH adjustment** or **T adjustment**.



5. Define the needed adjustment for the first measurement point:
  - a. Insert the probe head in the reference environment for the first calibration point.
  - b. Wait for the measurement to stabilize fully.
  - c. Click the **Reference value, point 1** text box and enter the reference value of the calibration point. Press **ENTER** or click outside the text box when done.
  - d. The module automatically enters the measured values for the calibration point.
6. If you want to adjust in more than one point, repeat [step 5](#) for all desired calibration points.



You can adjust humidity measurement in up to five points when Insight is set to **Advanced mode**.

7. Select **Activate adjustment > Yes** to store the adjustment in the module.
8. Check the message that appears at the top of the screen. If the message indicates that the adjustment is activated successfully, your adjustment is stored in the module.
9. Select the **Calibration information** tab and update the **Calibration date** and **Calibration text**.
10. Select **Close > Yes** to exit the calibration mode.

## 6. Technical data

### 6.1 HMM170 specifications

Table 7 Measurement performance

Property	Description/value
<b>Relative humidity</b>	
Measurement range	0 ... 100 %RH
Accuracy <sup>1) 2)</sup>	
at +15 ... +25 °C (59 ... +77 °F)	±1 %RH (0 ... 90 %RH) ±1.7 %RH (90 ... 100 %RH)
at -20 ... +40 °C (-4 ... +104 °F)	± (1.0 + 0.008 × reading) %RH
at -40 ... +180 °C (-40 ... +356 °F)	± (1.5 + 0.015 × reading) %RH
Factory calibration uncertainty at +20 °C (+68 °F) <sup>3)</sup>	±0.6 %RH (0 ... 40 %RH) ±1.0 %RH (40 ... 90 %RH) ±1.1 %RH (90 ... 95 %RH)
Humidity sensor types	HUMICAP® R2C HUMICAP® 180L2 HUMICAP® 180VC
T <sub>90</sub> response time <sup>4)</sup>	50 s with steel mesh filter 60 s with sintered filter
<b>Temperature</b>	
Measurement range	-70 ... +180 °C (-94 ... +356 °F)
Temperature sensor	Pt100 RTD Class F0.1 IEC 60751
Typical accuracy at +20 °C (+68 °F)	±0.2 °C (± 0.36 °F)

- 1) Including non-linearity, hysteresis and repeatability.
- 2) With HUMICAP® 180VC sensor, accuracy is not specified below -20 °C (-4 °F) operating temperature.
- 3) Defined as ±2 standard deviation limits. Small variations possible; see also calibration certificate.
- 4) At +20 °C (+68 °F) in 0.1 m/s air flow with Vaisala HUMICAP® R2C sensor.

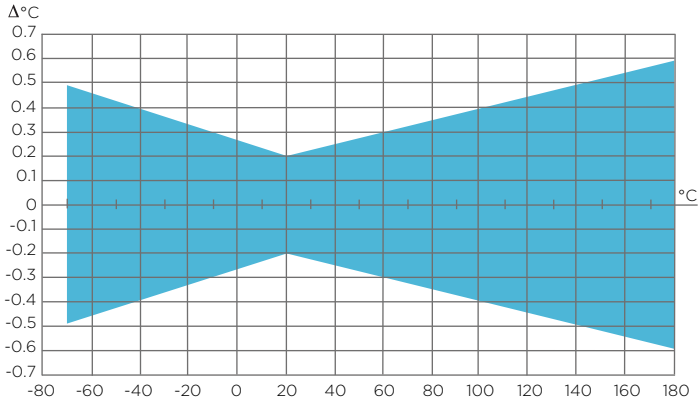

Figure 5 Temperature measurement accuracy over temperature range

Table 8 Operating environment

Property	Description/value
Operating temperature for component board	-40 ... +60 °C (-40 ... +140 °F)
Operating humidity for component board	0 ... 100 %RH, non-condensing
Storage temperature	-55 ... +80 °C (-67 ... +176 °F)
Operating pressure	0 ... 10 bar

Table 9 Inputs and outputs

Property	Description/value
Three analog outputs (selectable and scalable)	0 ... 20 mA, 4 ... 20 mA 0 ... 1 V, 0 ... 5 V, 1 ... 5 V, or 0 ... 10 V
Typical accuracy of analog output at +20 °C (+68 °F)	±0.05 % full scale
Typical temperature dependence of analog output	0.005 %/°C (0.003 %/°F) full scale
External load	$R_L < 500 \Omega$
Digital output	RS-485 serial, Modbus
Service port	M8 connector for USB cable
Start-up time	3 s at power-up
Wire size	0.5 ... 1.5 mm <sup>2</sup> (20 ... 16 AWG)
<b>Supply voltage</b>	

Property	Description/value
when condensation prevention and chemical purge features are not used	12 ... 35 VDC
all features available	18 ... 35 VDC or 24 VAC ±10 %
<b>Power consumption</b>	
Analog outputs	12 mA (voltage), 50 mA (current)
Chemical purge at 24 VDC	+220 mA
Warmed probe at 24 VDC	+240 mA

Table 10 Mechanical specifications

Property	Description/value
Weight with 2 m (6.5 ft) cable and stainless steel mesh filter	206 g (7.27 oz)
<b>Dimensions</b>	
Component board (H × W × D)	87.4 × 68.3 × 20 mm (3.44 × 2.69 × 0.79 in)
Cable length options	2 m (6.5 ft), 5 m (16.4 ft), and 10 m (32.8 ft)
Probe diameter	12 mm (0.47 in)
Probe length	99.5 (3.92 in)
<b>Materials</b>	
Component board	FR4
Cable jacket	FEP
Probe	AISI316L

## 6.2 Dimensions

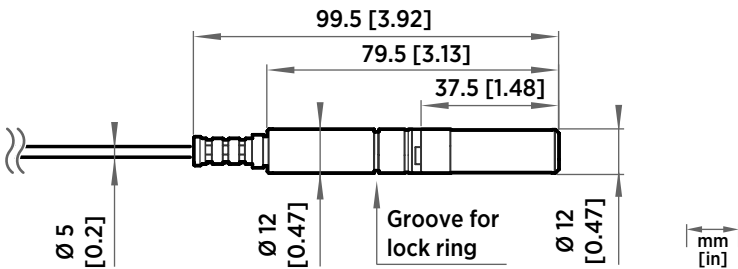

Figure 6 HMM170 probe head dimensions

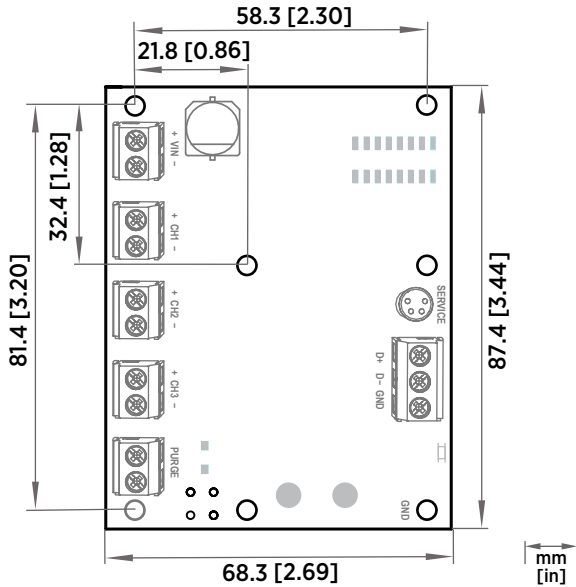

Figure 7 HMM170 component board dimensions

## 6.3 Accessories and spare parts

Table 11 Accessories

Item	Item code
USB cable for PC connection <sup>1)</sup>	219690
Cable gland M20×1.5 for probe cable	HMP247CG
Swagelok NPT 1/2" adapter for probe	SWG12NPT12
Swagelok ISO 1/2" adapter for probe	SWG12ISO12
Duct installation kit for probe	210697

1) *Vaisala Insight software for Windows available at [www.vaisala.com/insight](http://www.vaisala.com/insight)*

Table 12 Spare parts

Item	Item code
PPS plastic grid and stainless steel mesh filter	DRW01028ISP
Stainless steel sintered filter	HM4728OSP

Item	Item code
Sintered PTFE filter with 20 µm pore size	219452SP
Stainless steel filter	HM47453SP

## Appendix A. Modbus reference

### A.1 Default communication settings

Table 13 Default Modbus communication settings

Property	Description/Value
Serial bit rate	19200
Parity	None
Number of data bits	8
Number of stop bits	2
Flow control	None
Modbus device address	240

You can use up to ten probes on the same RS-485 line. You must configure each probe on the line to have a different Modbus address.

### A.2 Function codes

Table 14 Modbus function codes

Function code	Function code (hexadecimal)	Name
03	03 <sub>hex</sub>	Read Holding Registers
16	10 <sub>hex</sub>	Write Multiple Registers
43 / 14	2B <sub>hex</sub> / 0E <sub>hex</sub>	Read Device Identification

### A.3 Data encoding

In the data registers, the numeric values are available in one or two formats with separate register addresses: 32-bit IEEE floating point format and/or 16-bit signed integer format.



For values that have both 32-bit and 16-bit register available, use of the 32-bit register is recommended. Some values may exceed the signed 16-bit range even in normal operation.

### A.3.1 32-bit floating point or integer format

Registers using **32-bit float** data format are encoded using the **binary32** encoding defined in IEEE 754. The format is also known as "single-precision floating point format".

The least significant 16 bits of a floating point number are placed at the Modbus register listed in the table, while the most significant 16 bits are placed in the register with number/address + 1, as specified in Open Modbus TCP Specification, Release 1.0. This is also known as "little-endian" or "Modicon" word order.

Despite the specification, some Modbus masters may expect a "big-endian" word order (most significant word first). In such case, you must select "word-swapped" floating point format in your Modbus master for the Modbus registers of the device.



A complete 32-bit floating point or integer value should be read and written in a single Modbus transaction.



Reading the measurement data registers with incorrect floating point format setting may occasionally result in correct-looking values. It is highly recommended to verify that you have configured the floating point format correctly on your Modbus host system by reading a floating point value from a test value register.

#### More information

- [Test value registers \(page 39\)](#)

### A.3.2 16-bit integer format

Some 16-bit integer values in the data registers are scaled to include the necessary decimals. The scaling factors for those values are shown in the register tables.

Table 15 Interpretation of 16-bit signed integer values

Value	Description
0000 <sub>hex</sub> ... 7FFE <sub>hex</sub>	Value in range 0 ... 32766
7FFF <sub>hex</sub>	Value is 32767 or larger
8000 <sub>hex</sub>	Value is not available
8001 <sub>hex</sub>	Value is -32767 or smaller
8002 <sub>hex</sub> ... FFFF <sub>hex</sub>	Value in range -32766 ... -1 (2's complement)



## A.4 Modbus registers



**CAUTION!** Registers are numbered in decimal, starting from 1. Register addresses in actual Modbus messages (Modbus Protocol Data Unit (PDU) are in hexadecimal and start from zero. Subtract 1 from the register number presented in this manual to get the address used in the Modbus message. For example, register number 1 corresponds to address 0<sub>hex</sub> in the actual Modbus message. Please check the reference documentation of your Modbus host (PLC) for the notation of Modbus register addresses.

### A.4.1 Measurement data registers

Table 16 Modbus measurement data registers (Read-Only)

Register number	Address	Register description	Data format	Unit
<b>Floating point values</b>				
1	0000 <sub>hex</sub>	Relative humidity	32-bit float	%RH
	0001 <sub>hex</sub>			
3	0002 <sub>hex</sub>	Temperature	32-bit float	°C
	0003 <sub>hex</sub>			
7	0006 <sub>hex</sub>	Dew point temperature	32-bit float	°C
	0007 <sub>hex</sub>			
9	0008 <sub>hex</sub>	Dew/frost point temperature	32-bit float	°C
	0009 <sub>hex</sub>			
11	000A <sub>hex</sub>	Dew/frost point temperature at 1 atm	32-bit float	°C
	000B <sub>hex</sub>			
13	000C <sub>hex</sub>	Dew point temperature at 1 atm	32-bit float	°C
	000D <sub>hex</sub>			
15	000E <sub>hex</sub>	Absolute humidity	32-bit float	g/m <sup>3</sup>
	000F <sub>hex</sub>			
17	0010 <sub>hex</sub>	Mixing ratio	32-bit float	g/kg
	0011 <sub>hex</sub>			

Register number	Address	Register description	Data format	Unit
<b>Floating point values</b>				
19	0012 <sub>hex</sub>	Wet-bulb temperature	32-bit float	°C
	0013 <sub>hex</sub>			
21	0014 <sub>hex</sub>	Water concentration	32-bit float	ppm <sub>v</sub>
	0015 <sub>hex</sub>			
23	0016 <sub>hex</sub>	Water vapor pressure	32-bit float	hPa
	0017 <sub>hex</sub>			
25	0018 <sub>hex</sub>	Water vapor saturation pressure	32-bit float	hPa
	0019 <sub>hex</sub>			
27	001A <sub>hex</sub>	Enthalpy	32-bit float	kJ/kg
	001B <sub>hex</sub>			
29	001C <sub>hex</sub>	Water activity	32-bit float	a <sub>w</sub>
	001D <sub>hex</sub>			
31	001E <sub>hex</sub>	Dew point temperature difference	32-bit float	°C
	001F <sub>hex</sub>			
33	0020 <sub>hex</sub>	Absolute humidity at NTP	32-bit float	g/m <sup>3</sup>
	0021 <sub>hex</sub>			
35	0022 <sub>hex</sub>	Water concentration in oil	32-bit float	ppm <sub>w</sub>
	0023 <sub>hex</sub>			
41	0028 <sub>hex</sub>	Relative saturation	32-bit float	%
	0029 <sub>hex</sub>			
65	0040 <sub>hex</sub>	Water mass fraction	32-bit float	ppm <sub>w</sub>
	0041 <sub>hex</sub>			
<b>Integer values</b>				
257	0100 <sub>hex</sub>	Relative humidity	16-bit signed integer	%RH * 100
258	0101 <sub>hex</sub>	Temperature	16-bit signed integer	°C * 100

Integer values				
260	0103 <sub>hex</sub>	Dew point temperature	16-bit signed integer	°C * 100
261	0104 <sub>hex</sub>	Dew/frost point temperature	16-bit signed integer	°C * 100
262	0105 <sub>hex</sub>	Dew/frost point temperature at 1 atm	16-bit signed integer	°C * 100
263	0106 <sub>hex</sub>	Dew point temperature at 1 atm	16-bit signed integer	°C * 100
264	0107 <sub>hex</sub>	Absolute humidity	16-bit signed integer	g/m <sup>3</sup> * 100
265	0108 <sub>hex</sub>	Mixing ratio	16-bit signed integer	g/kg * 100
266	0109 <sub>hex</sub>	Wet-bulb temperature	16-bit signed integer	°C * 100
267	010A <sub>hex</sub>	Water vapor concentration	16-bit signed integer	ppm <sub>v</sub>
268	010B <sub>hex</sub>	Water vapor pressure	16-bit signed integer	hPa * 10
269	010C <sub>hex</sub>	Water vapor saturation pressure	16-bit signed integer	hPa * 10
270	010D <sub>hex</sub>	Enthalpy	16-bit signed integer	kJ/kg * 100
271	010E <sub>hex</sub>	Water activity	16-bit signed integer	a <sub>w</sub>
272	010F <sub>hex</sub>	Dew point temperature difference	16-bit signed integer	°C * 10
273	0110 <sub>hex</sub>	Absolute humidity at NTP	16-bit signed integer	g/m <sup>3</sup> * 100
274	0111 <sub>hex</sub>	Parts per million in oil	16-bit signed integer	ppm <sub>w</sub>
277	0114 <sub>hex</sub>	Relative saturation	16-bit signed integer	% * 100
289	0120 <sub>hex</sub>	Water mass fraction	16-bit signed integer	ppm <sub>w</sub>

## A.4.2 Configuration registers

Table 17 Modbus configuration data registers (writable)

Register number	Register address	Register description	Data format	Unit / Valid range
<b>General</b>				
1287	0506 <sub>hex</sub>	Extra heat on/off. Enables heating of humidity sensor when close to saturation. Measurement is disabled for the duration of heating and cooling.	16-bit boolean	0 = Off (default) 1 = On
1289	0508 <sub>hex</sub>	Probe heating on/off. When on, output parameters that depend on temperature measurement (for example, relative humidity) are disabled unless temperature is written to register 0334 <sub>hex</sub> from an external source.	16-bit boolean	0 = Off 1 = On
2561	0A00 <sub>hex</sub>	User information	Text	Text string of 24 bytes in UTF-8 encoding
	0A01 <sub>hex</sub>			
	0A02 <sub>hex</sub>			
	0A03 <sub>hex</sub>			
	0A04 <sub>hex</sub>			
	0A05 <sub>hex</sub>			
	0A06 <sub>hex</sub>			
	0A07 <sub>hex</sub>			
	0A08 <sub>hex</sub>			
	0A09 <sub>hex</sub>			
	0A0A <sub>hex</sub>			
0A0B <sub>hex</sub>				
<b>Compensation setpoints</b>				
769	0300 <sub>hex</sub>	Pressure compensation setpoint	32-bit float	Unit: hPa Default: 1013.25 hPa
	0301 <sub>hex</sub>			

<b>Compensation setpoints</b>				
821	0334 <sub>hex</sub>	Temperature compensation setpoint. If a value is written to this register, the device uses it instead of its own temperature measurement.  When probe heating is in use, temperature must be written to this register to enable output parameters that depend on temperature measurement (for example, relative humidity).	32-bit float	Unit: °C
	0335 <sub>hex</sub>			
<b>Purge</b>				
773	0304 <sub>hex</sub>	Purge interval	32-bit float	Unit: min 10 ... 14400
	0305 <sub>hex</sub>			
1283	0502 <sub>hex</sub>	Interval purge on/off	16-bit boolean	0 = Off 1 = On
1284	0503 <sub>hex</sub>	Startup purge on/off	16-bit boolean	0 = Off 1 = On
<b>Filtering</b>				
795	031A <sub>hex</sub>	Measurement filtering factor	32-bit float	Range: 0.000 ... 1.000 1.000 = Reading shows 100 % of the most recent measured value (no filtering, default). 0.01 ... 0.99 = Reading shows 1 ... 99 % of the most recent measured value and part of the previous reading (filtering is applied). For example, "0.9" means that the filtered measurement reading = 90 % of the most recent measured value + 10 % of the previous reading.
	031B <sub>hex</sub>			
1282	0501 <sub>hex</sub>	Enable or disable measurement filtering using the user-defined filtering factor (register 031A <sub>hex</sub> )	16-bit boolean	0 = Off 1 = On

Communication				
1537	0600 <sub>hex</sub>	Modbus address	16-bit integer	1 ... 247 Default: 240
1538	0601 <sub>hex</sub>	Bit rate	enum	0 = 300 1 = 600 2 = 1200 3 = 2400 4 = 4800 5 = 9600 6 = 19200 7 = 38400 8 = 57600 9 = 115200
1539	0602 <sub>hex</sub>	Parity, data, stop bits	enum	0 = None, 8, 1 1 = None, 8, 2 2 = Even, 8, 1 3 = Even, 8, 2 4 = Odd, 8, 1 5 = Odd, 8, 2 (default: 1 = None, 8, 2)
1540	0603 <sub>hex</sub>	Response delay	16-bit integer	Unit: ms Range: 0 ... 1000
Functions				
1285	0504 <sub>hex</sub>	Purge	16-bit function status	When writing to register: 1 = Activate purge
1542	0605 <sub>hex</sub>	Restart device	16-bit function status	When writing to register: 1 = Restart the device

### A.4.3 Device identification objects

Table 18 Device identification objects

Object id	Object id (hexadecimal)	Object name	Example contents
0	00 <sub>hex</sub>	VendorName	"Vaisala"

Object id	Object id (hexadecimal)	Object name	Example contents
1	01 <sub>hex</sub>	ProductCode	"HMM170"
2	02 <sub>hex</sub>	MajorMinorVersion	"1.2.3" Software version of the device.
3	03 <sub>hex</sub>	VendorUrl	"http://www.vaisala.com/"
4	04 <sub>hex</sub>	ProductName	"Vaisala HUMICAP(R) Humidity and Temperature Module HMM170"
5	05 <sub>hex</sub>	ModelName	"7E2A2A0A000" Configuration code of the device. Length and content of the code are model-specific.
6	06 <sub>hex</sub>	UserApplicationName	User definable information text (see configuration register 0A00 <sub>hex</sub> )
128	80 <sub>hex</sub>	SerialNumber <sup>1)</sup>	"K0710040"
129	81 <sub>hex</sub>	CalibrationDate <sup>1)</sup>	"2020-01-31" Calibration date in YYYY-MM-DD format. Empty string if not set/valid.
130	82 <sub>hex</sub>	CalibrationText <sup>1)</sup>	"Vaisala/HEL" Calibration information text. Empty string if not set/valid.

1) *Vaisala-specific device identification object.*

## A.4.4 Status registers

Table 19 Modbus status data registers (read-only)

Register number	Address	Register description	Data format	Note
513	0200 <sub>hex</sub>	Error status	16-bit boolean	0000 <sub>hex</sub> : One or more errors active 0001 <sub>hex</sub> : No errors
514	0201 <sub>hex</sub>	Online status	16-bit boolean	0000 <sub>hex</sub> : Output locked 0001 <sub>hex</sub> : Online data available
516	0203 <sub>hex</sub> 0204 <sub>hex</sub>	Error code	32-bit signed integer	See <a href="#">Table 20 (page 38)</a> .

Register number	Address	Register description	Data format	Note
518	0205 <sub>hex</sub>	Security hash	32-bit signed integer	Security hash changes when any change is made to device settings or adjustments.
	0206 <sub>hex</sub>			
520	0207 <sub>hex</sub>	RH measurement status	16-bit signed integer	0000 <sub>hex</sub> : Status OK 0002 <sub>hex</sub> : Reading is not reliable 0004 <sub>hex</sub> : Under range 0008 <sub>hex</sub> : Over range 0020 <sub>hex</sub> : Value locked 0080 <sub>hex</sub> : Sensor failure 0100 <sub>hex</sub> : Measurement not ready
521	0208 <sub>hex</sub>	T measurement status	16-bit signed integer	
522	0209 <sub>hex</sub>	Tdf measurement status	16-bit signed integer	
523	020A <sub>hex</sub>	Device status	16-bit signed integer	

Table 20 Error codes in register 0203<sub>hex</sub>

Bitmask	Error message	Severity
0000 <sub>hex</sub>	Status OK	
0001 <sub>hex</sub>	Temperature measurement error	Error
0002 <sub>hex</sub>	Humidity measurement error	Error
0004 <sub>hex</sub>	Humidity sensor failure	Error
0008 <sub>hex</sub>	Capacitance reference error	Error
0010 <sub>hex</sub>	Ambient temperature out of range	Error
800000 <sub>hex</sub>	Sensor heater failure	Warning



## A.4.5 Test value registers

Read the known test values from the test registers to verify the functionality of your Modbus implementation.

Table 21 Modbus test registers (read-only)

Register number	Register address	Register description	Data format	Test value
7937	1F00 <sub>hex</sub>	Signed integer test	16-bit integer	-12345
7938	1F01 <sub>hex</sub>	Floating point test	32-bit float	-123.45
	1F02 <sub>hex</sub>			
7940	1F03 <sub>hex</sub>	Text string test	text	Text string "-123.45"
	1F04 <sub>hex</sub>			
	1F05 <sub>hex</sub>			
	1F06 <sub>hex</sub>			

## A.5 Exception responses

Table 22 Modbus exception responses

Code	Name	Reason
01	ILLEGAL FUNCTION	Unsupported function code
02	ILLEGAL DATA ADDRESS	Address out of valid ranges
03	ILLEGAL DATA VALUE	Otherwise invalid request

Accessing unavailable (temporarily missing) measurement data does not generate a Modbus exception. "Unavailable" value (a quiet NaN for floating point data or 8000<sub>hex</sub> for integer data) is returned instead. An exception is generated only for any access outside the applicable register ranges.

## A.6 Modbus communication examples

### Reading relative humidity value



Device address used in the following examples is 240 (F0<sub>hex</sub>).  
 The values returned by the device differ depending on the ambient conditions and/or device settings. Your device might not return exactly the same values.

Request		Response	
Bytes on the line	Description	Bytes on the line	Description
(silence for 3.5 bytes)	Start of Modbus RTU frame	(silence for 3.5 bytes)	Start of Modbus RTU frame
F0 <sub>hex</sub>	Device address	F0 <sub>hex</sub>	Device address
03 <sub>hex</sub>	Function (Read Holding Registers)	03 <sub>hex</sub>	Function (Read Holding Registers)
00 <sub>hex</sub>	Register address	04 <sub>hex</sub>	Number of data bytes
00 <sub>hex</sub>		7A <sub>hex</sub>	Value of first register (least significant word)
00 <sub>hex</sub>	Number of 16-bit registers to read (2)	E1 <sub>hex</sub>	Value of second register (most significant word)
02 <sub>hex</sub>		41 <sub>hex</sub>	
D1 <sub>hex</sub>	Modbus RTU checksum	F4 <sub>hex</sub>	Modbus RTU checksum
2A <sub>hex</sub>		05 <sub>hex</sub>	
(silence for 3.5 bytes)	End of Modbus RTU frame	06 <sub>hex</sub>	End of Modbus RTU frame
		(silence for 3.5 bytes)	

Communication description	
Register address	1 (1-based Modbus documentation format) = 0000 <sub>hex</sub> (0-based format used in actual communication).
Data format	Two 16-bit Modbus registers interpreted as IEEE 754 binary32 floating point value, least significant word first.
Returned value	41F47AE1 <sub>hex</sub> , which is binary32 representation of 30.56 (%RH).

## Writing pressure compensation value

Request		Response	
Bytes on the line	Description	Bytes on the line	Description
(silence for 3.5 bytes)	Start of Modbus RTU frame	(silence for 3.5 bytes)	Start of Modbus RTU frame
F0 <sub>hex</sub>	Device address	F0 <sub>hex</sub>	Device address
10 <sub>hex</sub>	Function (Write Multiple Registers)	10 <sub>hex</sub>	Function (Write Multiple Registers)
03 <sub>hex</sub>	Register address	03 <sub>hex</sub>	Register address
00 <sub>hex</sub>		00 <sub>hex</sub>	
00 <sub>hex</sub>	Number of registers to write (2)	00 <sub>hex</sub>	Number of 16-bit registers written (2)
02 <sub>hex</sub>		02 <sub>hex</sub>	
04 <sub>hex</sub>	Number of data bytes	AD <sub>hex</sub>	Modbus RTU checksum
6E <sub>hex</sub>	Value for first register (least significant word)	54 <sub>hex</sub>	
14 <sub>hex</sub>			
44 <sub>hex</sub>	Value for second register (most significant word)	(silence for 3.5 bytes)	End of Modbus RTU frame
75 <sub>hex</sub>			
AB <sub>hex</sub>	Modbus RTU checksum	 <p>The response to a write function informs that the function was correctly received by the device. It does not guarantee that the written value was accepted by the device (for example, in case of out-of-range values).</p> <p>To verify that the value was really accepted by the device, read the register value after writing.</p>	
4E <sub>hex</sub>			
(silence for 3.5 bytes)	End of Modbus RTU frame		

Communication description	
Register address	769 (1-based Modbus documentation format) = 0300 <sub>hex</sub> (0-based format used in actual communication).
Data format	Two 16-bit Modbus registers interpreted as IEEE 754 binary32 floating point value, least significant word first.

Communication description	
Value to write	44756E14 <sub>hex</sub> = 981.72 (hPa)

## Warranty

For standard warranty terms and conditions, see [www.vaisala.com/warranty](http://www.vaisala.com/warranty).

Please observe that any such warranty may not be valid in case of damage due to normal wear and tear, exceptional operating conditions, negligent handling or installation, or unauthorized modifications. Please see the applicable supply contract or Conditions of Sale for details of the warranty for each product.

## Technical support



Contact Vaisala technical support at [helpdesk@vaisala.com](mailto:helpdesk@vaisala.com). Provide at least the following supporting information as applicable:

- Product name, model, and serial number
- Software/Firmware version
- Name and location of the installation site
- Name and contact information of a technical person who can provide further information on the problem

For more information, see [www.vaisala.com/support](http://www.vaisala.com/support).

## Recycling



Recycle all applicable material.



Follow the statutory regulations for disposing of the product and packaging.





**VAISALA**

[www.vaisala.com](http://www.vaisala.com)

